

HEATSTRIP[®]

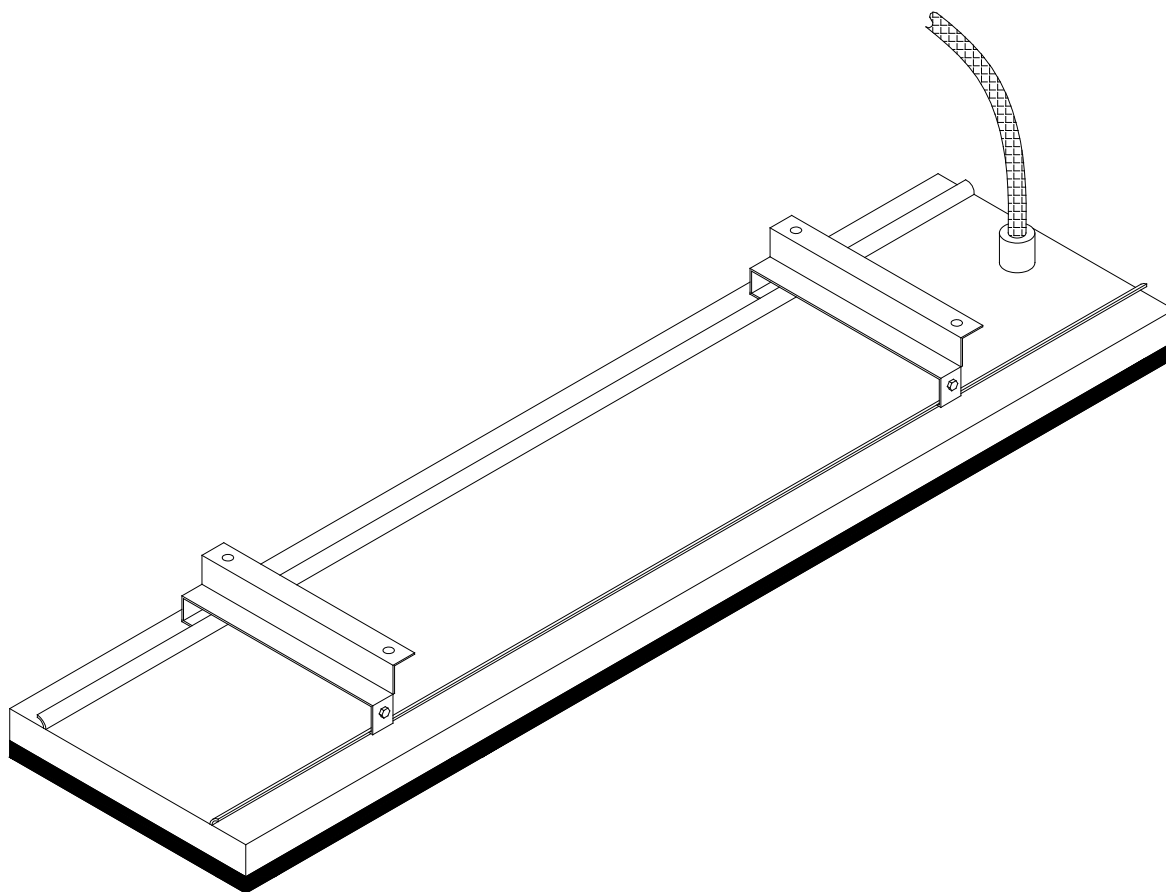

USER MANUAL

HEATSTRIP[®] Indoor THS-A



Superior Technology. Superior Style.

**Be Sure to Carefully Consult the User
Manual Before You Begin Using the Unit**

heatstrip.com.au

Thank You for Your Purchase!

Dear Customer,

Congratulations on the purchase of your new product from **HEATSTRIP®**

We recommend you please take some time to read the instruction manual thoroughly to familiarise yourself with the functionality and operations to ensure optimum performance of your new appliance.

After reading the manual, please store it in a safe and accessible location for future reference.

Installation

The installation of your new appliance must be carried out by a qualified installer / technician in accordance to local regulations. Please ensure all packaging materials are disposed of correctly.

Customer Care

Our Customer Care centre is available should you wish to learn more about your appliance in relation to how to use it to its best potential, or tips on maintenance, as well as available accessories.

Regards,

HEATSTRIP

For Further Details Please Contact Our Customer Care Team

Glen Dimplex Australia Pty Ltd
Ph: 1300 556 816 (AU) & 09 274 8265 (NZ)
HyperCare.Support@glendimplex.com.au
www.glendimplex.com.au

Contents

Features and Benefits	page 4
Safety	page 5
Specifications	page 6
Operating Cost Comparison	page 7
Selection Guide	page 8
INSTALLATION	
Installation Requirements	page 9
Installation Location	page 10
MOUNTING	
Mounting Options	page 11
Standard Mounting Brackets	page 12
Angle Mounting Brackets	page 13
Flush Mount Enclosure	page 14
OPTIONAL WALL CONTROLLER	
TT-MTM2 Wall Controller	page 15
TT-MTM2 Controller Installation Guide	page 17
Heater wiring schematic diagrams	page 18
MAINTENANCE AND WARRANTY	
Maintenance	page 19
Warranty and Terms and Conditions	page 20

Features and Benefits

Innovative, High Performance Electric Heating Technology

Stylish, Modern, Sleek, Slimline design

The new modern, slimline design of the Heatstrip Indoor makes it the sleekest profile on the market. It will elegantly and seamlessly blend into any indoor environment or décor.

Effective, efficient heating solution for all open indoor applications

The innovative design of the **HEATSTRIP® Indoor (THS-A)** enables comfortable and even heat dispersion from the surface with minimal operating costs.

Up to 90% of the heating energy is directed to the area to be warmed, while 10% is emitted as convective heat. This high efficiency ratio means greater heating value.

These medium intensity heaters have an improved water protection rating of IP45 and specifically designed for indoor heating.

Enhanced Heatstrip performance

The **HEATSTRIP® Indoor (THS-A)** design incorporates a unique profile with a high surface area to radiate the heat efficiently and effectively. The enhanced design of the heating panel ensures rapid heat dispersion to provide an ideal indoor comfort heat environment.

Design Flexibility to Meet BCA requirements

4 different models and multiple mounting options within the range allows for the design of innovative heating systems to meet stringent BCA requirements.

Suitable for Multiple Applications — commercial & residential

The **HEATSTRIP® Indoor (THS-A)** can be designed to provide comfort heating for a single room or a large stadium, and either a large group or a single person.

Heatstrip Indoor is ideal for a range of applications such as classrooms, lecture halls, sports facilities, shops, factories, churches, restaurant, warehouses, showrooms, child-care facilities, offices, industrial heating, dance & yoga studio's and bedrooms, living rooms, bathrooms etc.

Multiple Mounting Options allows for easy installation

Standard ceiling brackets are supplied, plus optional brackets are available for angled wall mounting, flush ceiling mounting; T-Bar ceiling mounting and chain/wire suspension mounting.

Minimal maintenance

The **HEATSTRIP® Indoor** incorporates no internal moving parts, ensuring quiet and virtually maintenance free operation.

Warranty

Designed and engineered in Australia, the **HEATSTRIP® Indoor** is fully backed by a 36 month residential warranty, and 24 month commercial warranty.

Safety

HEATSTRIP® Indoor (THS-A) has an IP rating of 45. This means it is safe for water ingress from all directions. The HEATSTRIP® can be safely given a light spray with a hose to keep clean.

HEATSTRIP® has undergone extensive testing both in laboratory conditions; in Glen Dimplex's manufacturing facility in Melbourne and field trials in Australia and overseas. It has been this testing that gives the purchaser the confidence of a high quality product.

Independent laboratory testing has confirmed Glen Dimplex's full compliance with Australian and other International Standards. This includes CE, AS/ANZ, UL/CSE

All heater models come with a plug. The fixed wiring must be installed by a licensed electrician in accordance with the relevant wiring regulations.

HEATSTRIP® is Class 1 equipment and must be earthed.

In operation, this heater is VERY HOT— do not touch any part of the heater while it is turned on. Do not touch any part until 30 minutes after it is turned off.

This appliance is not intended for use by persons (including children) with reduced physical, sensory or intellectual capabilities, or lack of experience and knowledge, unless they have been given supervision or instruction concerning use of the appliance by a person responsible for their safety. Children should be supervised to ensure they do not play with the appliance.

Do not allow any cables, furnishings, flammable materials or other items come in contact with any surface of the heater.

If installed in wet areas, the heater switches or controls must be located so that they cannot be touched by persons in the bath or shower.

The heater needs to be installed as per the installation instructions paying special attention to the minimum clearances. The heater needs to be mounted on a rigid bracket or fixing.

The heater must not be mounted immediately below or in front of a socket outlet.

In case of a heater fault or damaged supply lead, the appliance should be returned to the point of purchase for return to Glen Dimplex for repair.

Specifications - Australia

MODEL	POWER (Watts)	CURRENTS (Amps)	DIMENSIONS (mm)	WEIGHT (kg)	Lead Length (mm)	Plug
THS800A	800	3.3	624 x 235 x 48	4	1000	YES
THS1200A	1200	5.0	924 x 235 x 48	6	1000	YES
THS1800A	1800	7.5	1384 x 235 x 48	8	1000	YES
THS2400A	2400	10	1834 x 235 x 48	11	1000	YES

MODEL	
HEATER TYPE	High intensity electric radiant overhead heater with high surface area profiled alloy.
OUTPUT	800 watts/1200 watts/1800 watts/2400 watts
POWER	230-240 Volts Nominal at 50-60 Hertz, Single Phase
CONNECTION	3 Core Cable 2.5mm ²
APPROVALS	AUSTRALIA / NZ
MOUNTING HEIGHT	MINIMUM: 2.1 m RECOMMENDED: 2.3 m - 2.7 m MAXIMUM: 3m i n a fully enclosed outdoor area (For higher ceiling heights, units can be lowered using optional bracket kits or refer to the Heatstrip Max range)
MOUNTING OPTIONS	Suitable for ceiling, wall and recess mounting. Also available for suspension chain mount bracket.
PROTECTION RATING	IP45 Protection from water ingress from all directions.
MATERIALS OF CONSTRUCTION	High temperature coated aluminium alloy.

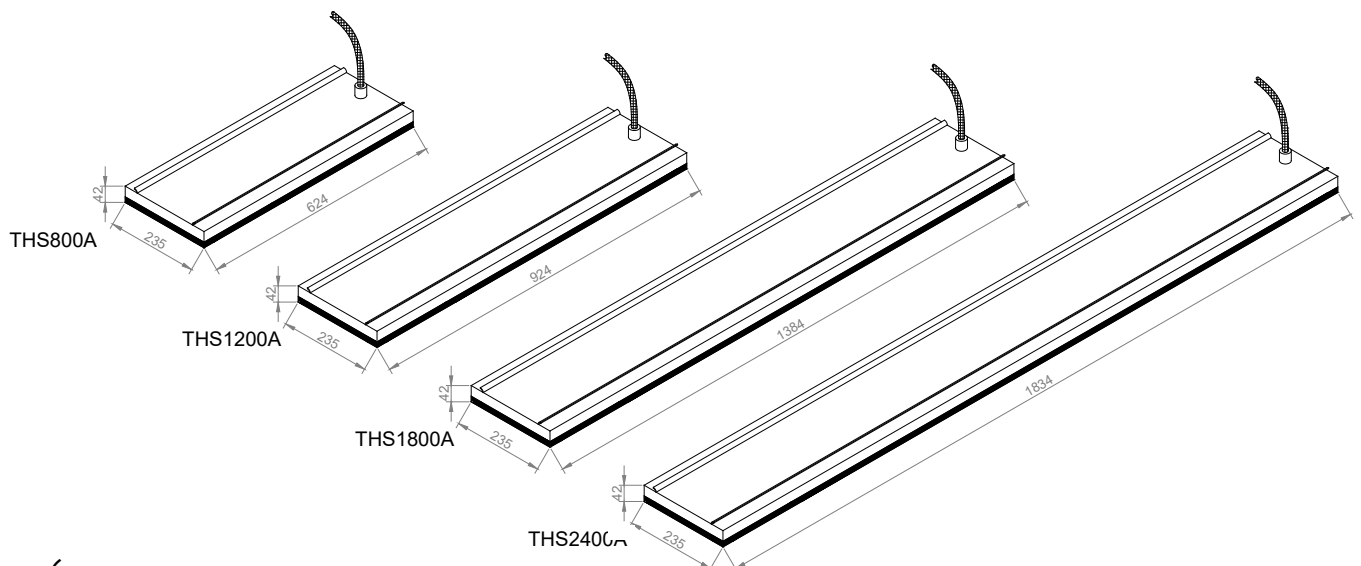

Operating cost comparison

In many instances, patio heaters powered by gas bottles are used as an outdoor heating source. The below table shows the operational cost comparison between HEATSTRIP® and a bottled gas outdoor heater. Not only are the hourly running costs considerably less with HEATSTRIP®, but you never have to worry about running out of gas, no refilling, no unattractive gas bottle to waste space; and HEATSTRIP® actually improves the value of your property.

Running Cost	Outdoor Gas Heater	HEATSTRIP ELECTRIC RADIANT HEATER			
		THS800A	THS1200A	THS1800A	THS2400A
PER HOUR	\$2.78/hr	\$0.22/hr	\$0.34/hr	\$0.50/hr	\$0.67/hr
PER YEAR	\$500.40	\$39.60	\$61.20	\$90.00	\$120.60

Notes:

- Calculations of hourly running cost for outdoor gas heater is based on \$25.00 average to fill a 9kg gas bottle and average running time of 9 hours. $\$25.00 / 9 \text{ hours} = \2.78 per hour
- Electricity rate of 28.0 cents/kWh
- All calculations are excluding GST.
 - 800W x 0.28 cents = \$0.22 or 22 cents per hour
 - 1200W x 0.28 cents = \$0.34 or 34 cents per hour
 - 1800W x 0.28 cents = \$0.50 or 50 cents per hour
 - 2400W x 0.28 cents = \$0.67 or 67 cents per hour

Calculations of yearly running cost are based on 180 hours usage

- 180 hours x \$2.78 = \$500.40 yearly running cost for outdoor gas heater
- 180 hours x \$0.22 = \$39.60 yearly running cost for 800W Heatstrip
- 180 hours x \$0.34 = \$61.20 yearly running cost for 1200W Heatstrip
- 180 hours x \$0.50 cents = \$90.00 yearly running cost for 1800W Heatstrip
- 180 hours x \$0.67 cents = \$120.60 yearly running cost for 2400W Heatstrip

Selection Guide

General recommendation for **HEATSTRIP® Indoor (THS-A)**:

- Minimum mounting height: 2.1m
- Ideal mounting height: 2.3m to 2.7m
- Maximum mounting height: 3m
- Ideal mounting location: Ceiling mounted, directly above area to heated.
(e.g above a table)

The below table outlines the coverage of each **HEATSTRIP® Indoor (THS-A)** model (in m²), based on 2 different scenarios.
For example, for an indoor area that is protected, Model THS1800A will cover 12m² and Model THS2400A will cover 16m².

For angled wall mounting applications, the coverage is reduced by up to 40%.

MODEL	Indoor Insulated (m ²)	Indoor Protected (m ²)
THS800A	8	5
THS1200A	12	8
THS1800A	18	12
THS2400A	24	16



Installation Requirements

The ideal mounting position for the **HEATSTRIP® Indoor (THS-A)** is on the ceiling directly above the area to be heated. If this is not possible, HEATSTRIP® can be mounted on a wall and angled downwards. In this situation, ensure the mounting height is in the range of 2.1m to 3m

For mounting heights more than 3m, we recommend the use of the optional accessories to reduce the height of the heater to 2.3m—2.5 m. This will increase the effectiveness of your **HEATSTRIP®**. Refer to the Mounting Accessory section for more information.

Electrical connections/GPO's should not be located at the back of the heater. They should be located outside the physical footprint of the units to minimize heat build-up behind the units.

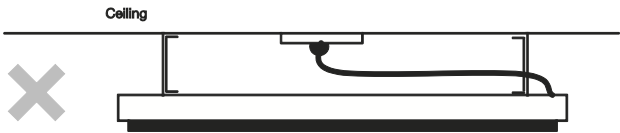
If the heater is to be mounted on an incline (e.g. vaulted ceiling), ensure the electrical connection is located at the lowest point of the heater.

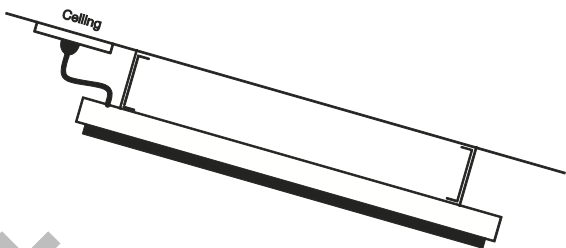
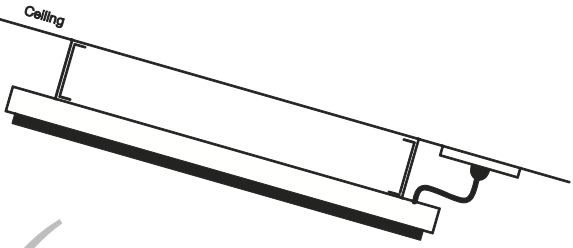
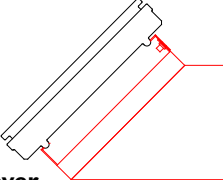
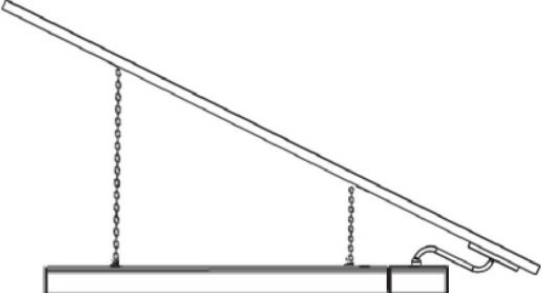
Incorrect Installation	Correct Installation
 <p>×</p>	 <p>✓</p>
 <p>×</p>	 <p>✓</p>
<p>CEILING</p>  <p>The heating surface must never be directed toward the ceiling</p> <p>×</p>	 <p>✓</p>

Installation Location

The below diagrams confirm the minimum recommended clearances.

Angled Wall Installation

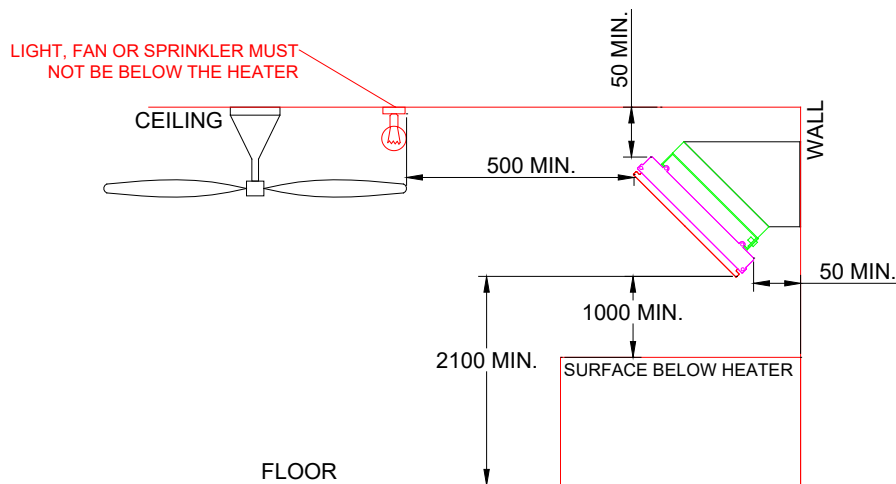

Ceiling Installation

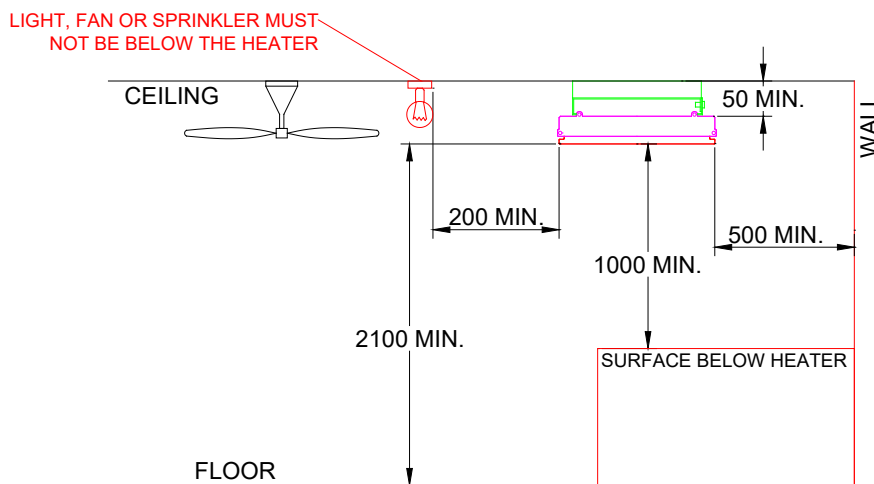

Angled Ceiling Installation

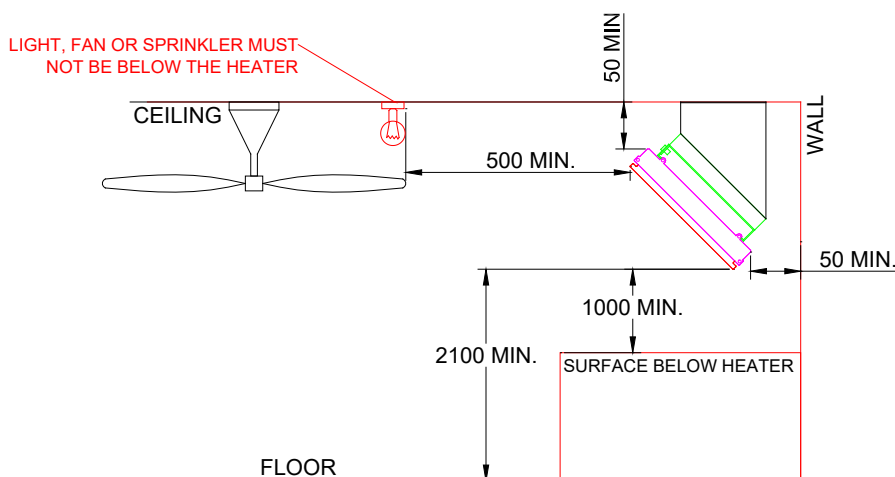

Mounting Options

The installation of **HEATSTRIP® Indoor (THS-A)** is simple and easy with the standard mounting brackets supplied. For other, more challenging locations there are a range of mounting options available - refer to below diagrams.

The **HEATSTRIP® Indoor (THS-A)** can be mounted directly to the ceiling; angled downwards on a wall; fitted flush with the ceiling or suspended on chains. Refer to the following pages for more detailed information on each mounting option.

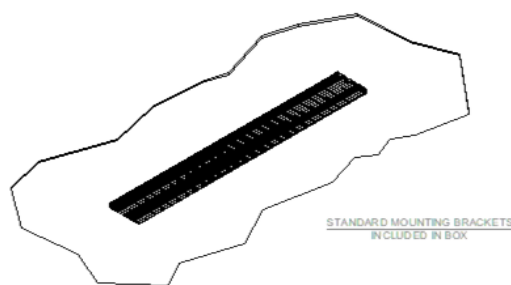
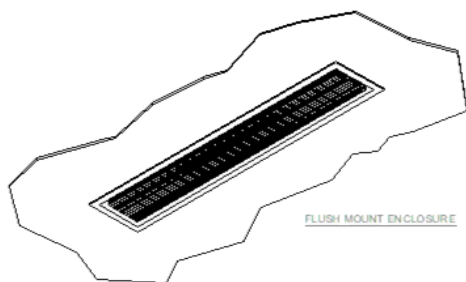
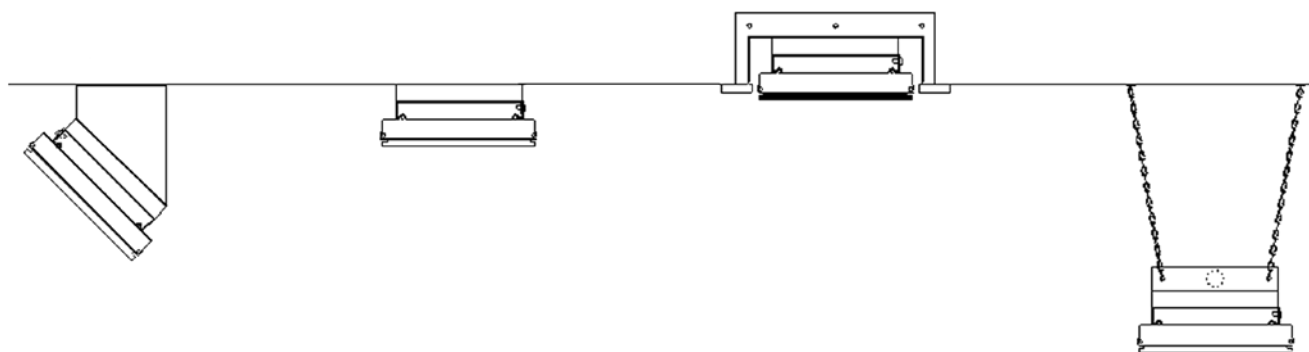

Standard Mounting Bracket

The **HEATSTRIP® Indoor (THS-A)** comes with a pair of standard mounting brackets. These brackets allow direct ceiling mount.

The brackets need to be mounted onto a secure frame or ceiling with a minimum distance between the two brackets. The minimum distance (“B”) for each model is listed in the table below.

When completing the installation, ensure all screws are tight and unit is secure.

MODEL	“X” MINIMUM DISTANCE (mm)
THS800A	350
THS1200A	500
THS1800A	700
THS2400A	1000

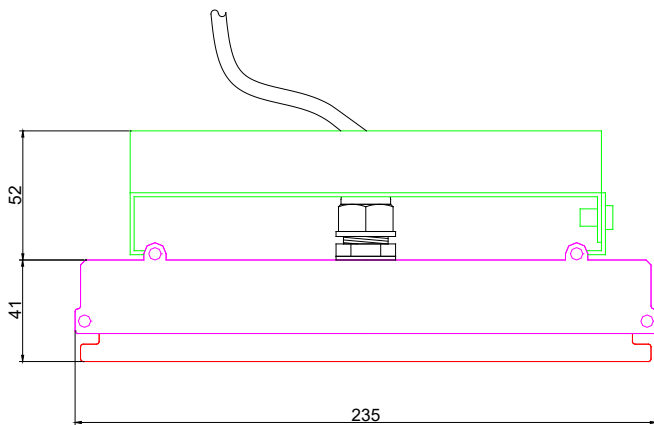
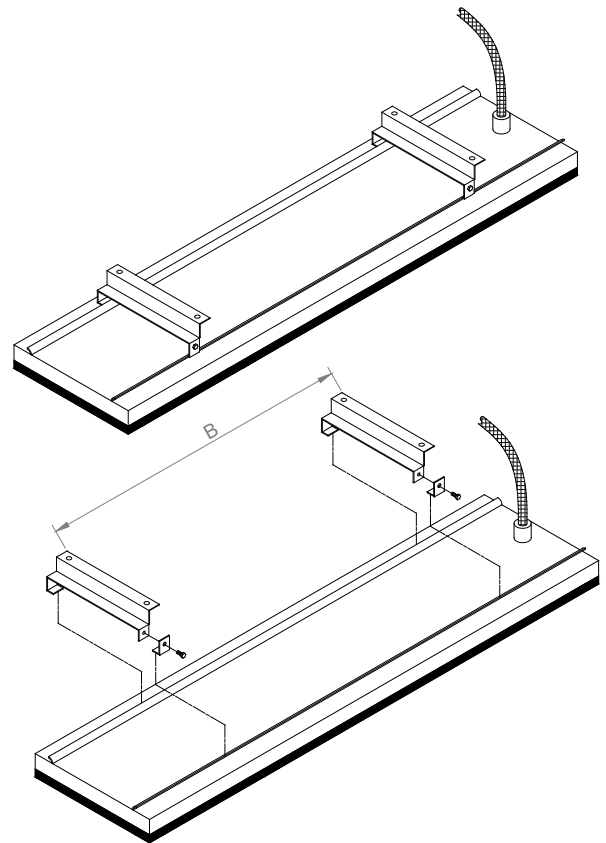

Part No.	Packaged (mm)	Weight (Kg)	Materials
ZBRAK-92	200 x 50 x 50	0.5	Mild Steel Powder-Coated White

Angle Mounting Brackets

The **HEATSTRIP® Indoor (THS-A)** has optional angle mounting brackets. These brackets can be mounted to the ceiling or the wall to bring the effective heat closer to where it is needed.

The angle of the bracket is preset to 45°.

When installing, ensure that the minimum distances are maintained. Screws are not provided.

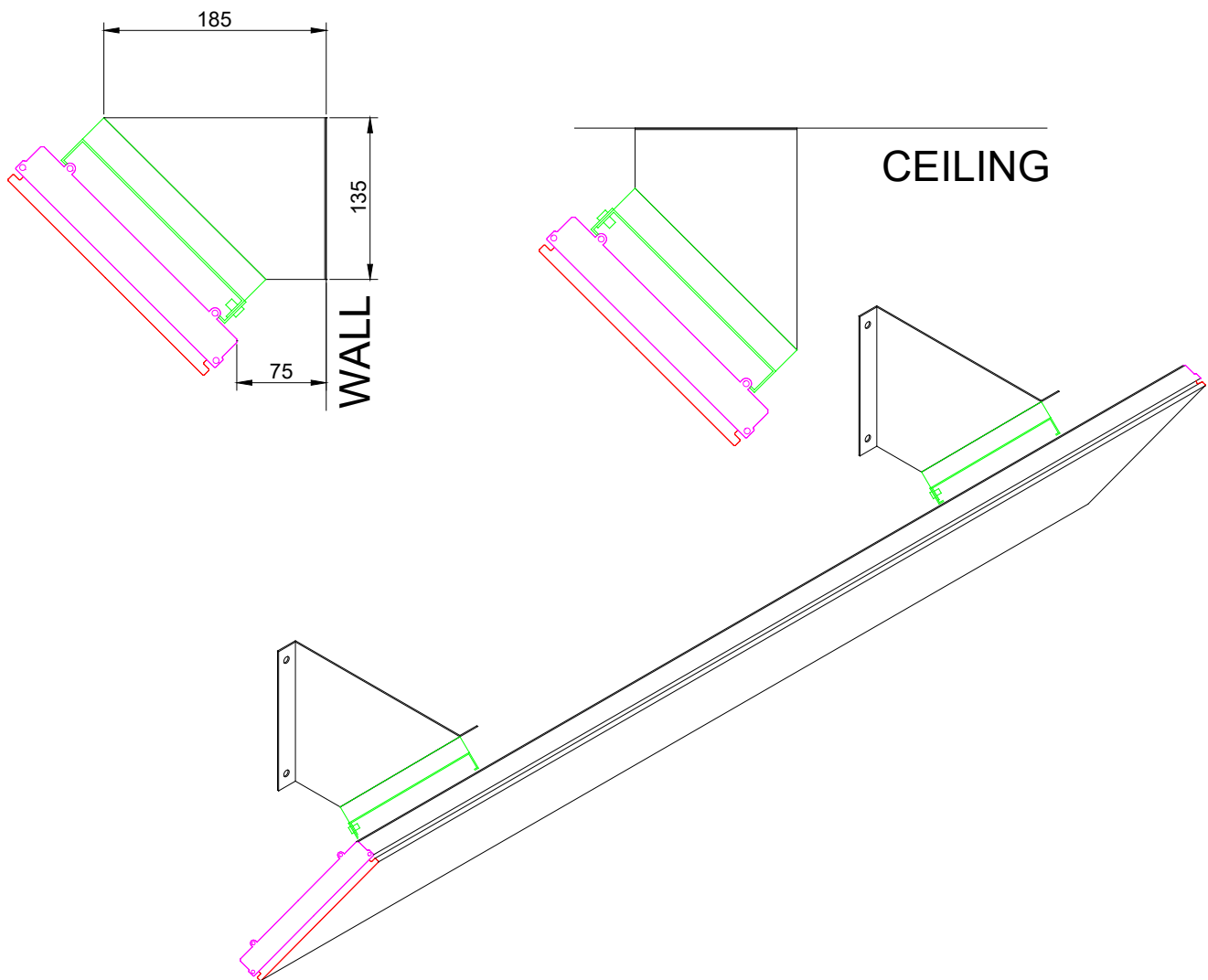

Part No.	Packaged (mm)	Weight (Kg)	Materials
THSAC-020	200 x 200 x 50	0.5	Mild Steel Powder-Coated White

Flush Mount Enclosure

The Flush Mount Enclosure is an ideal way to neatly install the **Heatstrip® Indoor (THS-A)** into a ceiling. They are available for all **Heatstrip® Indoor (THS-A)** models, and are supplied as a one-piece unit for mounting of heaters. Flush mounting can used with plaster or wood lined ceiling materials.

An ideal mounting height is 2.1 - 2.7m. Maximum mounting heights should be strictly followed, otherwise the performance of the units may be reduced.

The fascia is made from white powder coated mild steel.

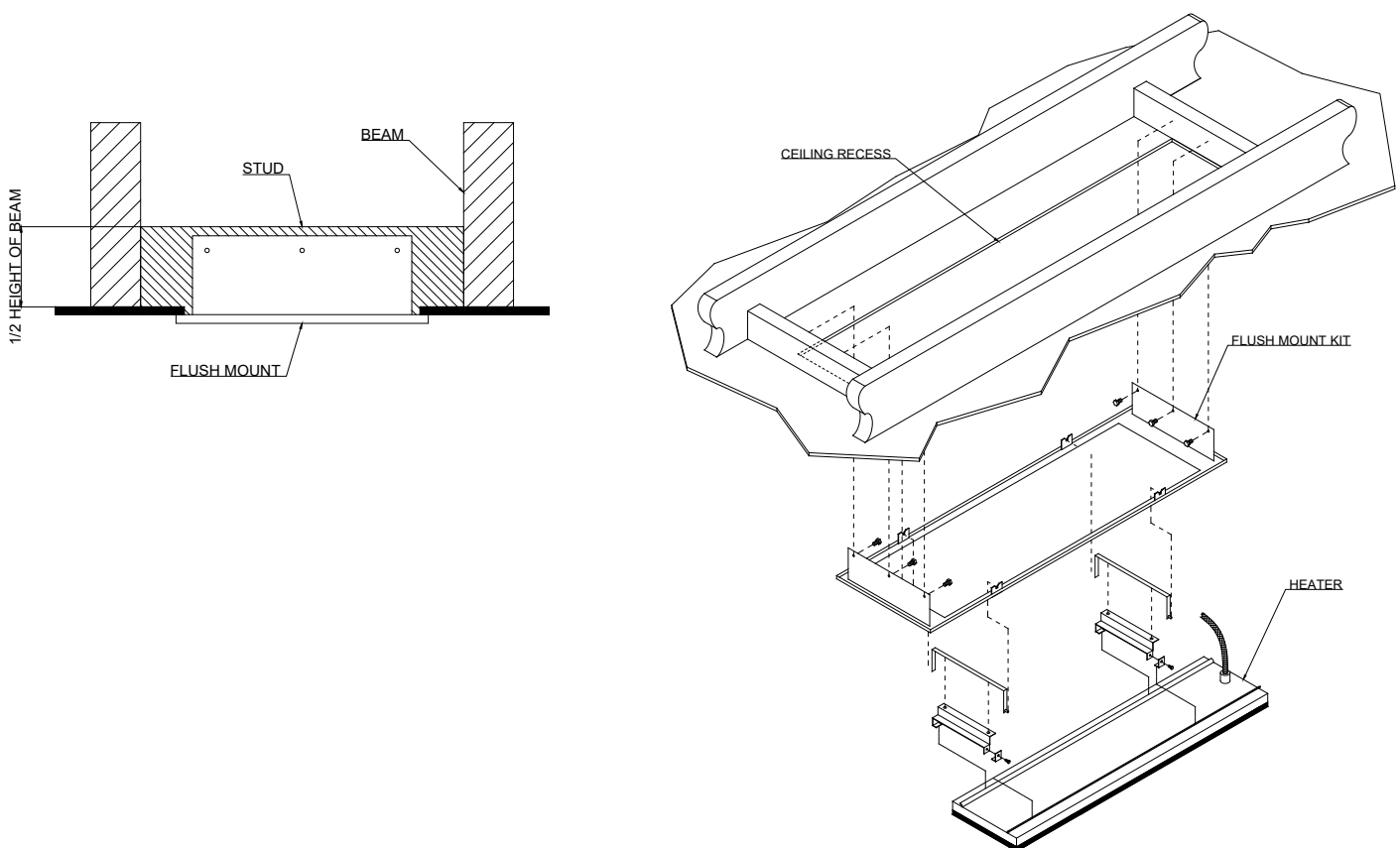

Suitable for Model	Part No.	Hole Cutout Dimensions (mm)	Overall Dimensions (mm)	Weight (kg)
THS800A	THSAC-025	720L x 300W	740L x 345W x 100D	4
THS1200A	THSAC-026	1020L x 300W	1040L x 345W x 100D	4
THS1800A	THSAC-027	1480L x 300W	1500L x 345W x 100D	5
THS2400A	THSAC-028	1930L x 300W	1950L x 345W x 100D	5

HEATSTRIP® Wall Mounted Controller with Remote

TT-MTM2 Wall Controller

This controller is a custom designed and manufactured controller for **HEATSTRIP®** heaters. It has been designed for ease of use and to provide low running costs of your heater. It provides both temperature control (allowing the user to turn the heat output up or down depending on the ambient temperature and conditions) and a timer for automatic heater shut-off operation.

The timer function has 4 settings: 1 hour, 2 hours, 4 hours or constantly on. This feature is ideal for applications such as BBQ areas, alfresco areas, restaurant dining, assembly line production etc. When continuous heat is not required. The timer also reduces the likelihood of heaters being inadvertently left turned on.

Depending on the ambient temperature there may be a requirement to control the heat output of the heater. The controller has 3 settings, they are High, Medium and Low.

The controller allows a combination of the multiple timer (1/2/4 hour) and heat outputs (High/Medium/Low)

Controlling multiple heaters

It is possible to use one wall controller to control multiple heaters not exceeding 16A. The wall controller is rated at 16 Amps and 240 volts.

Remote

All **TT-MTM2** units operate using the same remote control frequency, therefore, multiple wall controllers can be operated using a single remote control.

The remote will function at distances of **over 8m when used in a straight line pointed at the wall controller**, This distance reduces when used at an angle.



Model	Maximum Voltage (Volts)	Maximum Current (Amps)	Packaged Dimensions	Unit Weight (kg)
TT-MTM2	240	16	150W x 95L x 55D mm	0.3

HEATSTRIP Wall Mounted Controller with Remote

Operation

Press “On/Off” button to turn power on and off.

Once turned on, the controller will default to High power setting and will be permanently on (no timer function). Press “POWER” button to select the desired power setting by cycling through HIGH—MEDIUM—LOW. When power setting is at high the controller will provide continuous power. When power setting is at “MEDIUM” or “LOW” the output alternates between being on and off so that it delivers a lower output to the heater. Press “TIMER” button to set the timer to 1,2,4 hours or permanently on. When permanently on, one of the TIMER LED’s will be illuminated. Once the timer is selected, the timer will be started immediately. When the timer has ended, power will turn off and all LED’s will also turn off.

Thermal Cut-Out Protection

This controller is protected by a thermal cut-out switch. This switch is activated when the temperature of the controller is too high. The controller will cut all power until it has sufficiently cooled. Once it cools the unit will continue working as usual.

Warm Up Mode

The controller is programmed to operate continuously (High setting) for the first 15 minutes of operation regarding less of the selected power setting, this is to allow time for the heater to warm up. After this time it will operate as selected.

Safety

The TT-MTM2 controller is to be mounted indoors it needs to be away from wet conditions. Ensure the connections are properly connected. The controller needs to be installed according to your local wiring guidelines and regulations . Do not allow any cables, furnishings, flammable materials or other items to obstruct the vents of the controller.

Never block the air vents of the controller. Do not put anything in the vents of the controller.

The appliance is not intended for use by persons (Including children) with reduced physical, sensory or intellectual capabilities, or lack of experience and knowledge , unless they have been given supervision or instruction concerning use of the appliance by person responsible for their safety. Children should be supervised to ensure they do not play with the appliance.

Maintenance

The TT-MTM2 Controller is made from durable materials, however regular care and maintenance of your controller will help prolong the life of the product. It is recommended that you dust the controller to keep the surface clean. Cleaning at least every three months will reduce the amount of dust build up and keep it looking at its best. Do not use any abrasive materials or products to clean the controller, this includes solvents, citrus based cleaners or other harsh cleaning products. Do not use water or a damp cloth to clean the controller. The remote uses 2 AAA batteries. If the red light on the remote stops working then change the battery.

TT-MTM CONTROLLER INSTALLATION GUIDE

Controller Wiring Example

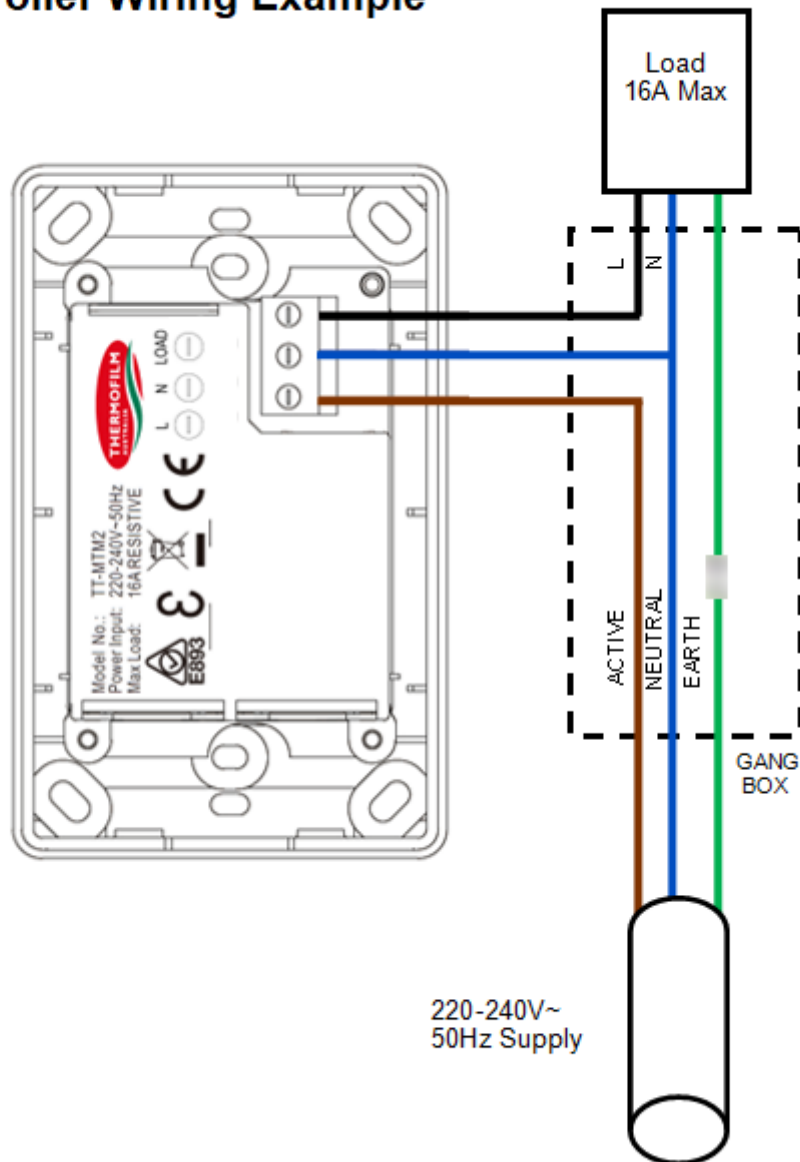

The TT-MTM2 Controller required sufficient air circulation in order to provide continuous operation on the high power load setting. The vents must always remain clear; never block or cover the vents. An ideal controller installation will provide significant space around the back of the controller. Installing into restricted spaces, such as brick walls, may result in overheating if adequate ventilation is not provided.

Heater wiring schematic diagrams

It is recommended to install an ON/OFF isolation switch before the controller and ensure the unit is turned OFF after use. Multiple heaters can be operated using a single controller, however the maximum current rating of 16A must not be exceeded. For direct wiring to the controller, the maximum is generally on heater unit unless the combined maximum current is less than 16A. For example, 2x THH1800A can be connected directly to the controller.

Below are example circuits indicating potential installation configurations. Always check with your electrician and ensure all wiring is in accordance with local regulations.

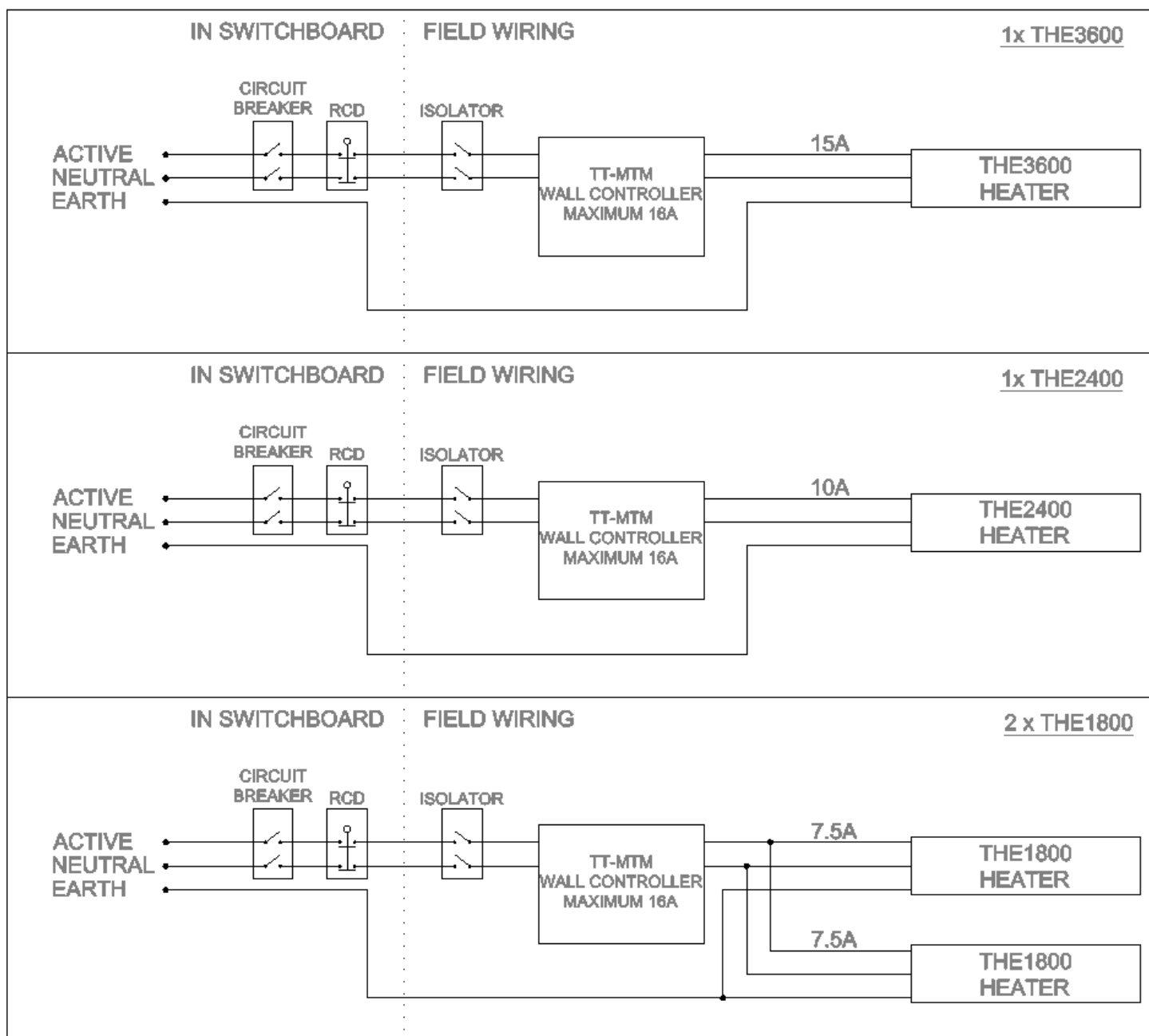

Maintenance

The **HEATSTRIP®** is made from durable materials, however regular care and maintenance of your heater will help prolong the life of the heater.

It is recommended that you clean the heater and with a soft cloth. Gently wipe the surfaces of the heater with a warm water to remove the built up contaminants from the environment. Then rinse all detergent off the heater.

All chemicals in the atmosphere including cigarette smoke, pollution etc. will tarnish the surface of the heater. In this case, additional cleaning and maintenance may be required. The cleaning process at least every three months will reduce the amount of build up and keep it looking as best it can. If the heater is in a corrosive environment eg. salt spray, we recommend that you clean your heater with a light spray of fresh water every week. After cleaning, turn the heater on for 20 minutes to dry any water residue and prevent water staining.

Before cleaning or inspection activity, the heater must be switched off and cooled down completely.

Do not use any abrasive materials or products to clean the heater, this includes solvents, citrus based cleaners or other harsh cleaning products.

When handling the heater, ensure that your hands are clean or that you use clean gloves as grease or dirt can mark the surface of the heater.

Do not use high pressure water to clean heaters, light water spray only.

Warranty Terms & Conditions

The below Warranty Terms and Conditions apply for **New Zealand and Australia only**. For international warranty please refer to international warranty terms and conditions.

Glen Dimplex warrants to the original owner that HEATSTRIP® Indoor (THS-A) products will be free from defects in materials and workmanship for a period of 36 months for residential applications and 24 months for commercial applications, from the date of purchase in accordance with the following warranty terms and conditions.

Provision of this warranty is subject to:

- The HEATSTRIP® product must be installed in accordance with the Installation Instructions and relevant electrical standards and codes.
- The HEATSTRIP® product must be maintained and cleaned according to instructions detailed in the Installation Manual.
- There is no warranty expressed or implied with regard to capacity requirements. The selection of the unit or units depends entirely upon the system design and capacities as determined by the purchaser.
- The customer has not repaired, opened or altered the product in any unauthorised manner.
- This warranty excludes damage to the product or components arising from circumstances outside the control of Glen Dimplex, including, but not limited to, where the product is not used for intended purpose; where the product has been rectified in any way; incorrect installation; incorrect power supply; damaged caused during delivery; misapplication, misuse, abuse, vandalism, lack of maintenance or accident.
- Glen Dimplex's obligations under this warranty are limited to repair or replacement at Glen Dimplex's factory of any components of the product which Glen Dimplex identifies to its satisfaction to be defective.
- Transportation charges involved in return of the product to the Glen Dimplex factory (or any other location authorised in writing by Glen Dimplex) is the sole responsibility of the customer.
- All products are inspected and tested before despatch and are at the risk of the purchaser after the shipment from the Glen Dimplex factory, if not delivered by Glen Dimplex to destination.
- Discolouration of the surface may occur after a period of time, this does not constitute a warrantable event.
- Twisting and bending of the heaters may occur, this does not constitute a warrantable event.
- No products or components will be supplied in advance of an examination of the faulty product or components by Glen Dimplex or an authorized representative of Glen Dimplex.
- Glen Dimplex does not participate in any site related costs or labour expenses incidental to replacement of parts, repairing, removing, installing, servicing, transportation or handling of parts to complete products, and assumes no liability on parts repaired or replaced without written authorisation. Glen Dimplex shall not be liable for any default or delay in performance of its warranty obligations caused by any circumstances beyond its control, including, but not limited to, judicial or government restrictions, strikes, fires, floods, abnormal weather conditions, delayed supply of components.

Should products be determined as damaged on arrival, immediately notify the transport company of the condition and have them noted on the freight documents. If damage is discovered after unpacking, demand immediate inspection by the transportation company and insist that a record of the damage is made on the freight documentation.

The customer warrants using the product in accordance with:

- Any instructions provided to it by Glen Dimplex from time to time.
- All government and local regulations, including but not limited to all relevant electrical, environmental laws and regulations governing the installation, storage, use, handling and maintenance of the goods.
- All necessary and appropriate precautions and safety measures relating to the installation, storage, use, handling and maintenance of goods.

Our goods come with guarantees that cannot be excluded under the Australian Consumer Law. You are entitled to a replacement or refund for a major failure and for compensation for any other reasonably foreseeable loss or damage.

You are also entitled to have the goods repaired or replaced if the goods fail to be of acceptable quality and the failure does not amount to a major failure.

All warranty requests for repairs or replacements must be accompanied by a complete "Warranty Claim Form" available from Glen Dimplex, together with proof of purchase (and where possible, photos of the installation) and the heater returned to the place of purchase.

In the event of a warranty claim, the goods need to be returned to the distributor/retailer for repair/replacement. Contact

Glen Dimplex Australia Pty Ltd
8 Lakeview Dr Scoresby, Victoria 3179, Australia
Telephone: 1300 556 816 (AU) & 09 274 8265 (NZ)
Email: HyperCare.Support@glendimplex.com.au

