

# HEATSTRIP<sup>®</sup>

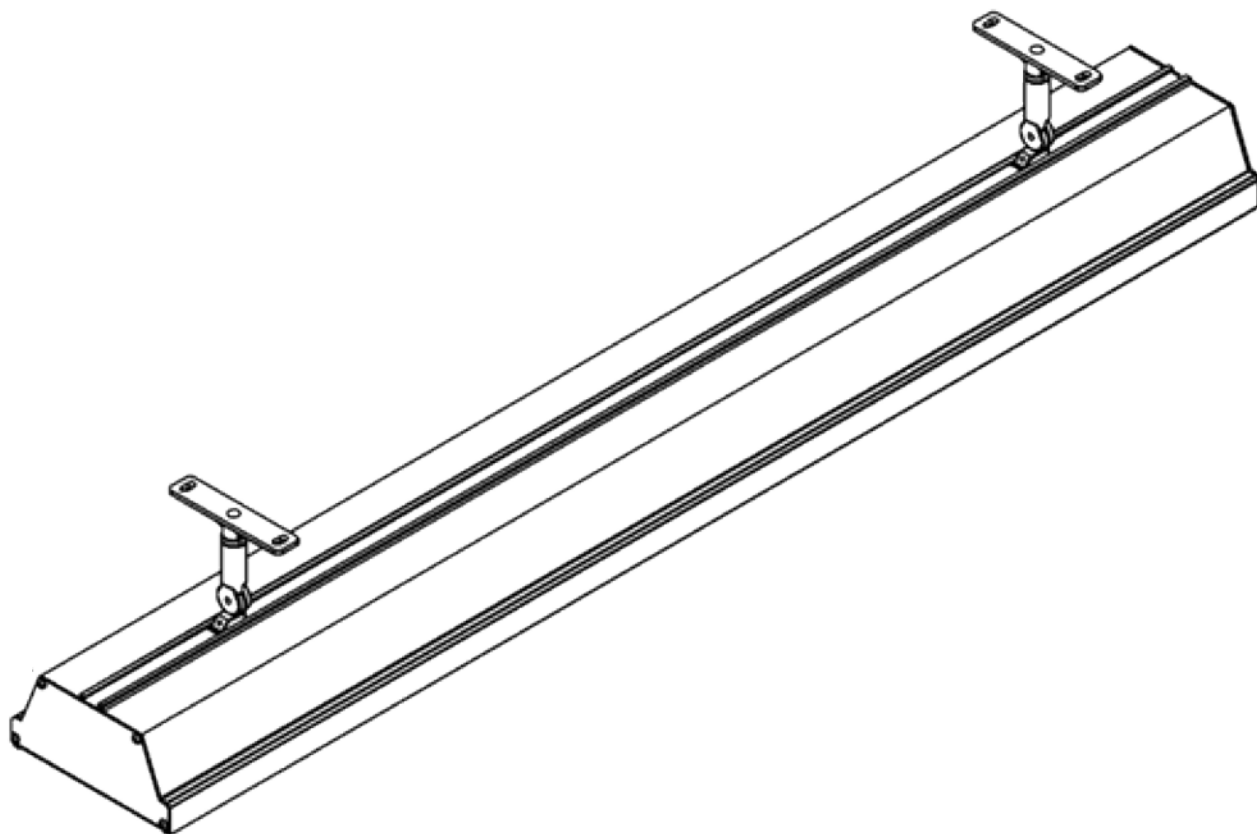

## USER MANUAL

### HEATSTRIP<sup>®</sup> MAX DC - Commercial THX-DC



*Superior Technology. Superior Style.*

**Be Sure to Carefully Consult the User  
Manual Before You Begin Using the Unit**

heatstrip.com.au



## Thank You for Your Purchase!

Dear Customer,

Congratulations on the purchase of your new product from **HEATSTRIP<sup>®</sup>**

We recommend you please take some time to read the instruction manual thoroughly to familiarise yourself with the functionality and operations to ensure optimum performance of your new appliance.

After reading the manual, please store it in a safe and accessible location for future reference.

### **Installation**

The installation of your new appliance must be carried out by a qualified installer / technician in accordance to local regulations. Please ensure all packaging materials are disposed of correctly.

### **Customer Care**

Our Customer Care centre is available should you wish to learn more about your appliance in relation to how to use it to its best potential, or tips on maintenance, as well as available accessories.

Regards,

**HEATSTRIP**

---

### **For Further Details Please Contact Our Customer Care Team**

Glen Dimplex Australia Pty Ltd  
Ph: 1300 556 816 (AU) & 09 274 8265 (NZ)  
HyperCare.Support@glendimplex.com.au  
www.glendimplex.com.au

## Contents

Features and Benefits	page 4
Safety	page 5
Specifications	page 6
Operating Cost Comparison	page 7
<b>SPOT HEATING</b>	
Spot Heating Principal	page 8
Radiant Footprint	page 9
Selection Guide	page 10
Table Layout	Page 11
<b>INSTALLATION</b>	
Installation Requirements	page 12
Installation Location	page 13
<b>MOUNTING</b>	
Mounting Options	page 14
Standard Mouting Brackets	page 15
Mounting	page 16
Extension Mounting Bracket	page 17
<b>MAINTENANCE AND WARRANTY</b>	
Maintenance	page 18
Warranty and Terms and Conditions	page 19

## Features and Benefits

*Innovative, High Performance Electric Heating Technology*

### **High Output radiant heat**

The **HEATSTRIP® Max DC** range of electric radiant infrared heaters produces a high temperature radiant warmth that travels through the air directly to people and surfaces below – similar to the heat rays emitted by the Sun. Radiant heating is the only viable option for outdoor or tough indoor sites.

### **Dual Glass Element Design**

Specially designed and engineered with a dual glass elements, which deliver high intensity instant infrared heat. Ideal for coastal or hard to heat applications.

### **Maximum heat performance – multiple applications**

The high temperature output of the **HEATSTRIP® Max DC** is perfect for exposed outdoor sites, high ceilings and hard-to-heat indoor and outdoor applications.

The dual element design allows for a very compact unit, and maximum efficiency.

Outdoor applications include alfresco and dining/entertainment areas, patios, veranda's and balconies, to name a few. Indoor applications such as factories, warehouses, show-rooms, workshops and workstation spot heating are ideal for the **HEATSTRIP® Max DC**.

### **Suitable for permanent outdoor mounting, no protection needed.**

For outdoor applications, the **HEATSTRIP® Max DC** is suitable for both permanently exposed (eg. courtyards and patios) and undercover installations - does not need to be fully protected from the elements.

### **Corrosion protection**

The **HEATSTRIP® Max DC** is suitable for use in most applications, including difficult corrosive environments such as coastal areas.

### **Multi-Purpose Mounting Options**

The **HEATSTRIP® Max DC** is supplied with flexible mounting options. The standard bracket will allow both ceiling and wall mounting, at various angles, as well as suspension by chains/wires. Extension poles and flush mounts are available as optional accessories.

### **2 models – hard-wired**

2 models are available. The THX4000DC (4000W) & THX6000DC (6000W) require hard-wiring supply.

The THX4000DC (4000W) require hard-wiring to 20amp power supply

The THX6000DC (6000W) requires hard-wiring to 32Amp power supply.

### **Warranty**

It is fully supported by a 3 year commercial warranty.

## Safety

**HEATSTRIP® Max DC (THX-DC)** has an IP rating of X5. This means it is safe for water ingress from all directions. The HEATSTRIP® can be safely given a light spray with a hose to keep clean.

**HEATSTRIP®** has undergone extensive testing both in laboratory conditions; in Glen Dimplex's manufacturing facility in Melbourne and field trials in Australia and overseas. It has been this testing that gives the purchaser the confidence of a high quality product.

Independent laboratory testing has confirmed Glen Dimplex's full compliance with Australian and other International Standards. This includes CE, AS/ANZ, UL/CSE

The heater comes in hardwired (4000W & 6000W) versions. In both cases the fixed wiring must be installed by a licensed electrician in accordance with the relevant wiring regulations.

**HEATSTRIP®** is Class 1 equipment and must be earthed.

In operation, this heater is VERY HOT— do not touch any part of the heater while it is turned on. Do not touch any part until 30 minutes after it is turned off.

This appliance is not intended for use by persons (including children) with reduced physical, sensory or intellectual capabilities, or lack of experience and knowledge, unless they have been given supervision or instruction concerning use of the appliance by a person responsible for their safety. Children should be supervised to ensure they do not play with the appliance.

Do not allow any cables, furnishings, flammable materials or other items come in contact with any surface of the heater.

If installed in wet areas, the heater switches or controls must be located so that they cannot be touched by persons in the bath or shower.

The heater needs to be installed as per the installation instructions paying special attention to the minimum clearances. The heater needs to be mounted on a rigid bracket or fixing.

The heater must not be mounted immediately below or in front of a socket outlet.

In case of a heater fault or damaged supply lead, the appliance should be returned to the point of purchase for return to Glen Dimplex for repair.

### Specifications - Australia

MODEL	POWER (Watts)	CURRENTS (Amps)	DIMENSIONS (mm)	WEIGHT (kg)	Lead Length (mm)	Plug
THX4000DC	4000	16.6	1134 x 170 x 80	5	1500	NO
THX6000DC	6000	25	1274 x 170 x 80	6	1500	NO

MODEL	
HEATER TYPE	High intensity electric radiant, infra-red overhead heater with dual glass element.
OUTPUT	4000 watts or 6000 watts
POWER	230-240 Volts Nominal at 50—60 Hertz, Single Phase 230-240 Volts Nominal at 50—60 Hertz, Three Phase
CONNECTION	3 Core Cable 4.0mm <sup>2</sup>
APPROVALS	AUSTRALIA / NZ
MOUNTING HEIGHT	MINIMUM: 2.4 m RECOMMENDED: 2.5 m - 2.8 m MAXIMUM: 3m Outdoors
MOUNTING OPTIONS	Suitable for ceiling, wall, beam mounting. Also available for extension mount using rigid fixing poles, chain mount bracket & kits.
PROTECTION RATING	IPX5 Protection from water ingress from all directions
MATERIALS OF CONSTRUCTION	Anodised alloy casing and end caps with a powder coated grille (Black)

**THX4000DC**

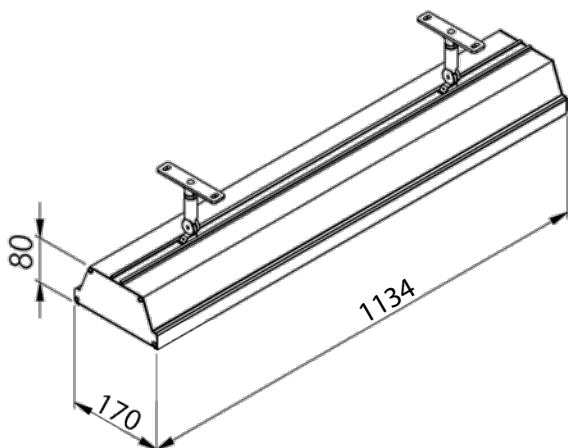

**THX6000DC**

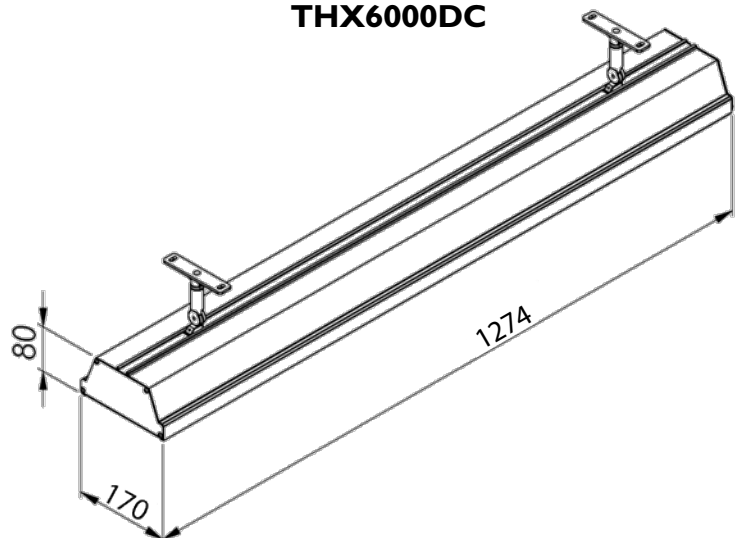

### Operating cost comparison

In many instances, patio heaters powered by gas bottles are used as an outdoor heating source. The below table shows the operational cost comparison between HEATSTRIP® and a bottled gas outdoor heater. Not only are the hourly running costs considerably less with HEATSTRIP®, but you never have to worry about running out of gas, no refilling, no unattractive gas bottle to waste space; and HEATSTRIP® actually improves the value of your property.

Running Cost	Outdoor Gas Heater	HEATSTRIP ELECTRIC RADIANT HEATER	
		THX4000	THX6000
PER HOUR	\$2.78/hr	\$1.12/hr	\$1.68/hr
PER YEAR	\$500.40	\$201.60	\$302.40

**Notes:**

- Calculations of hourly running cost for outdoor gas heater is based on \$25.00 average to fill a 9kg gas bottle and average running time of 9 hours.  $\$25.00 / 9 \text{ hours} = \$2.78 \text{ per hour}$
- Electricity rate of 28.0 cents/kWh
- All calculations are excluding GST.  
 $4.0\text{kW} \times 0.28 \text{ cents} = \$1.12 \text{ or } 112 \text{ cents per hour}$   
 $6.0\text{kW} \times 0.28 \text{ cents} = \$1.68 \text{ or } 168 \text{ cents per hour}$

Calculations of yearly running cost are based on 180 hours usage  
 $180 \text{ hours} \times \$2.78 = \$500.40 \text{ yearly running cost for outdoor gas heater}$   
 $180 \text{ hours} \times \$1.12 = \$201.60 \text{ yearly running cost for } 4000\text{W Heatstrip}$   
 $180 \text{ hours} \times \$1.68 = \$302.40 \text{ yearly running cost for } 6000\text{W Heatstrip}$

## Spot Heating Principle

In most outdoor or difficult-to-heat indoor applications, there are 2 methods when looking at the size and quantity of heaters required.

**Option 1** is to spot heat the high use areas, such as over outdoor tables, BBQ's, lounges, assembly lines or indoor workstations.

**Option 2** is to comfort heat the entire area based on the total dimensions of the space, regardless of whether the entire area is being fully occupied or not.

Often it is more practical and efficient to spot heat these areas. Spot heating will help to reduce the initial capital cost, as well as the on-going running costs. Spot heating will allow the area to be “zoned”, meaning heating only the areas that are being used, such as tables in a restaurant or outdoor alfresco area.

### Option 1

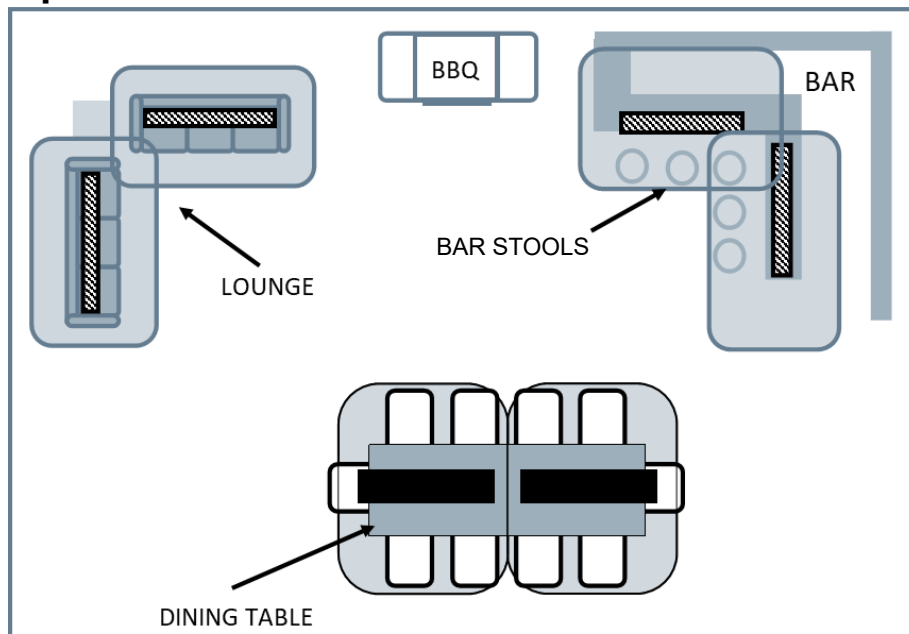

### Option 2

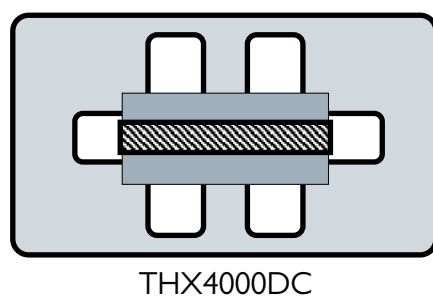

THX4000DC

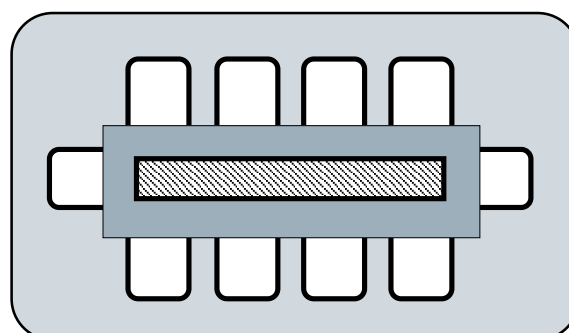

THX6000DC

## Radiant footprint

**HEATSTRIP® Max DC** electric heaters produce radiant heat, which heats objects rather than the air. Therefore, it is imperative that objects to be heated (ie. people), are within the direct radiant footprint of the heater.

The diagram below shows the radiant footprint of **HEATSTRIP® Max DC**, and is an approximate guide based on a fully enclosed, outdoor environment.

This diagram shows that the maximum heat output is found directly under the heater, and the temperature decreases as you move away from the heater.

It highlights the importance of maintaining recommended mounting heights, and positioning the heater directly above the area to be heated, if possible.

Also, the temperature (ie. surface temperature) is the same for both models, regardless of the wattage. However, as the size increases and the length of the unit increases, the radiant footprint will be larger.

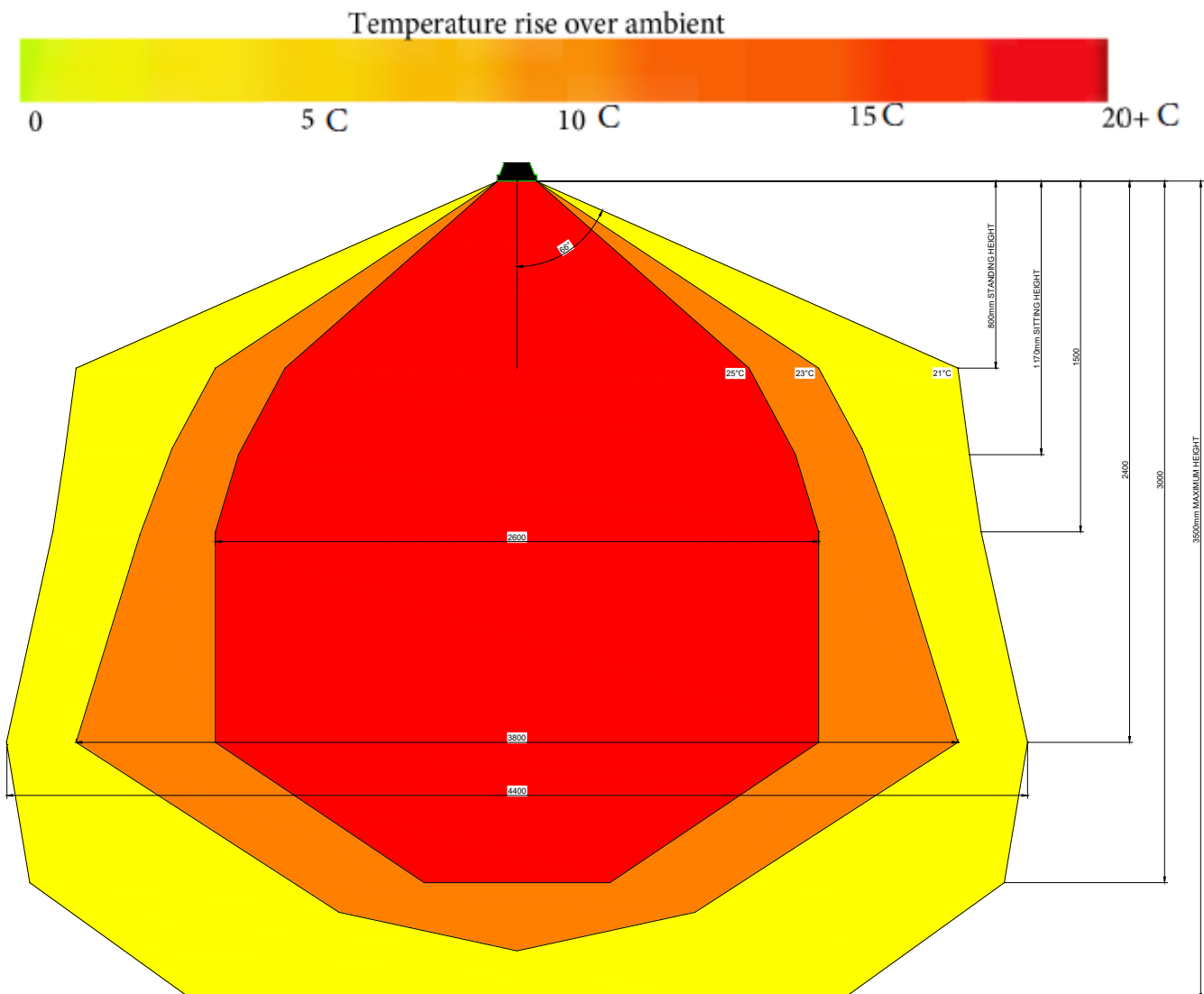

### Selection Guide

General recommendation for **HEATSTRIP® MAX (THX-DC)**:

- Ideal mounting height: 2.5m to 2.8m. Maximum is 3.0m Outdoors.
- Ideal mounting location: ceiling mounted, directly above area to be heated (Eg. above a table)

The below table outlines the coverage of each **HEATSTRIP® Max DC** model (in m<sup>2</sup>), based on 3 different scenarios. For example, in an outdoor area that is protected from prevailing winds by walls, café blinds etc, (eg outdoor enclosed), Model THX4000DC will cover 12m<sup>2</sup> and Model THX6000DC will cover 16m<sup>2</sup>. This data is based on direct overhead ceiling mounting. If the heaters are wall mounted, the radiant footprint will be reduced.

MODEL	Outdoor Exposed (m <sup>2</sup> )
THX4000DC	12
THX6000DC	16

Above data is based on direct overhead ceiling mounting. If the heaters are wall mounted, the radiant footprint may be reduced.

The below diagrams show the approximate heating area for each model, based on both an indoor protected, outdoor enclosed and outdoor exposed location.

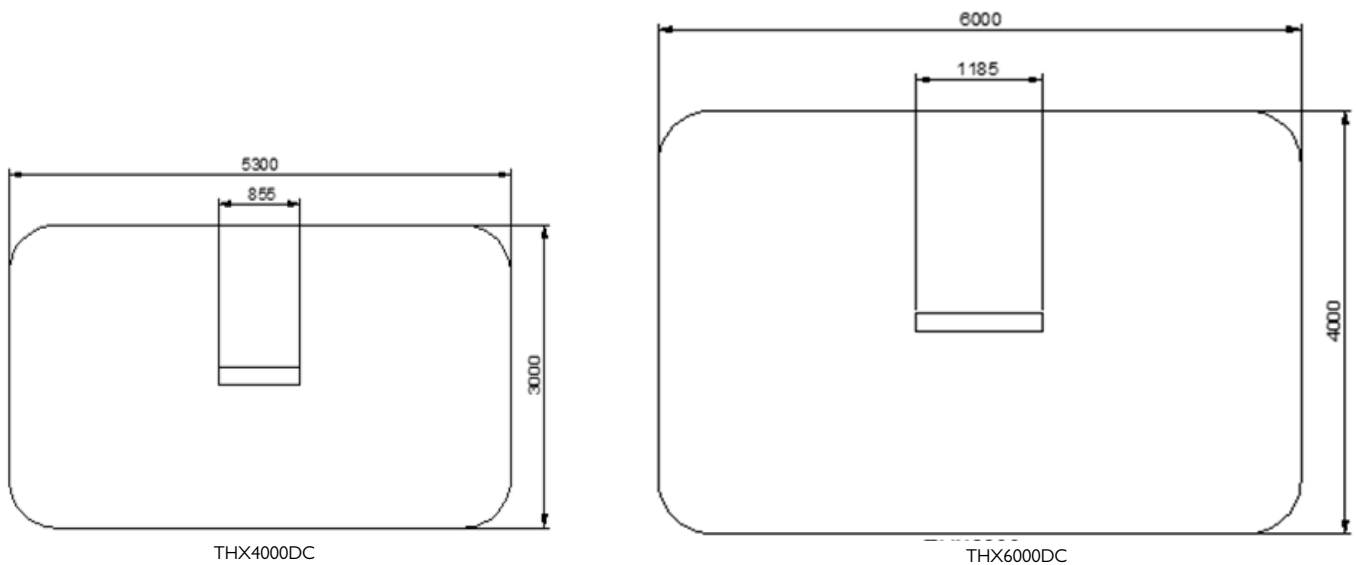

## Table Layout

General recommendation for **HEATSTRIP® MAX (THX-DC)**:

- Minimum mounting height: 2.4m
- Ideal mounting height: 2.5m to 2.8m
- Maximum mounting height: 3m
- Ideal mounting location: Ceiling mounted, directly above area to heated.  
(e.g above a table)

For the majority of outdoor applications, the most effective method is to spot heat a table or similar area. The below diagrams provides an easy selection guide for the approximate model and quantity of heaters required to heat common table settings

Selections are based on **HEATSTRIP® Max DC** being mounted at 2.7m from the floor and an undercover fully enclosed outdoor area.

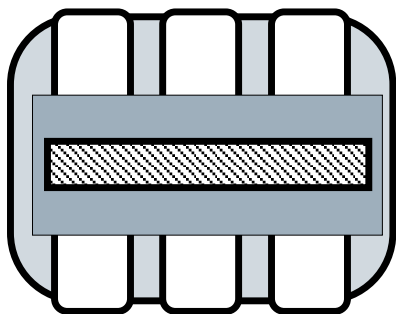

THX400DC

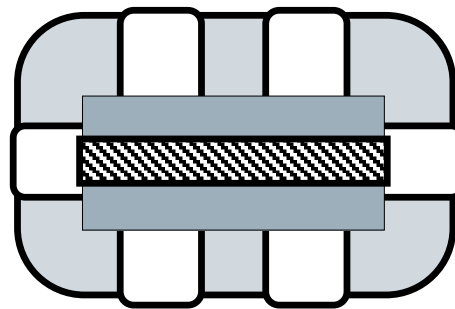

THX6000DC

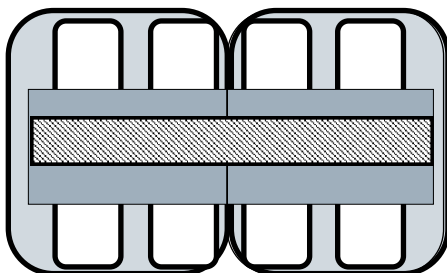

THX6000DC

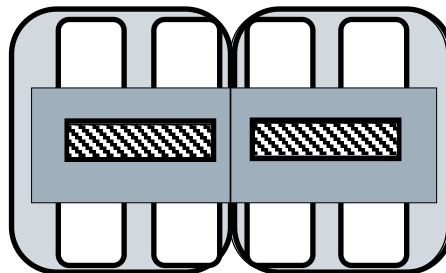

2 x THX400DC



### Installation Requirements

The ideal mounting position for the **HEATSTRIP® Max DC** is on the ceiling, directly above the area to be heated. If this is not possible, **HEATSTRIP® Max DC** can be mounted on a wall and angled downwards. In this situation, ensure the mounting height is in the range of 2.5m to 2.8m and the table is within 1- 2m of the wall.

For mounting heights more than 3.0m outdoors, we recommend the use of the optional accessories to reduce the height of the heater to 2.5m—2.8 m. This will increase the effectiveness of your **HEATSTRIP®**. Refer to the Mounting Accessory section for more information.

Electrical connections/GPO's should not be located at the back of the heater. They should be located outside the physical footprint of the units to minimize heat build-up behind the units.

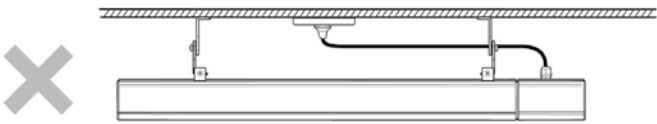
**The HEATSTRIP® Max (THX-DC) is not suitable for mounting on an incline, along the length. recommendation**

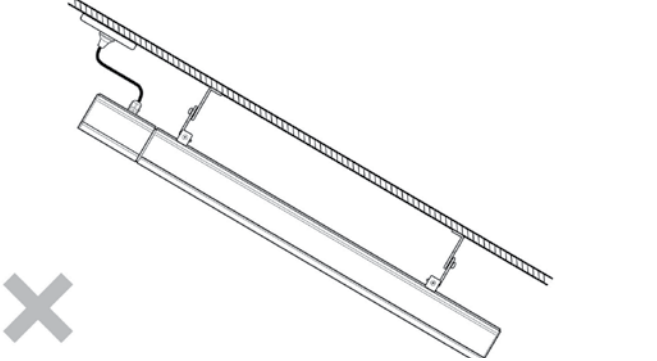
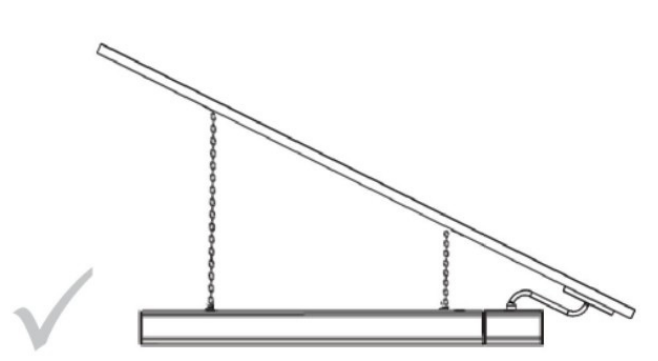
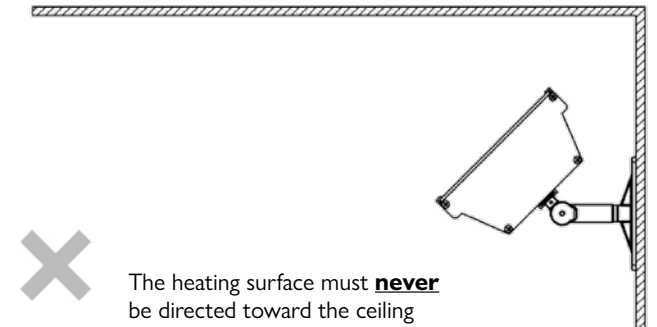
Incorrect Installation	Correct Installation
	
	
 <p data-bbox="240 2029 555 2085">The heating surface must <b>never</b> be directed toward the ceiling</p>	

## Installation Location

The below diagrams confirm the minimum recommended clearances.

### Angled Wall Installation

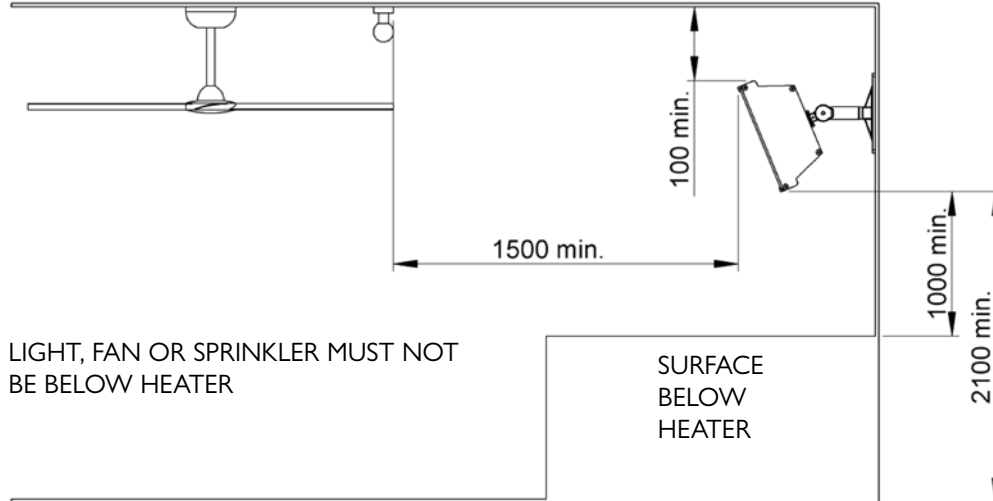

### Ceiling Installation

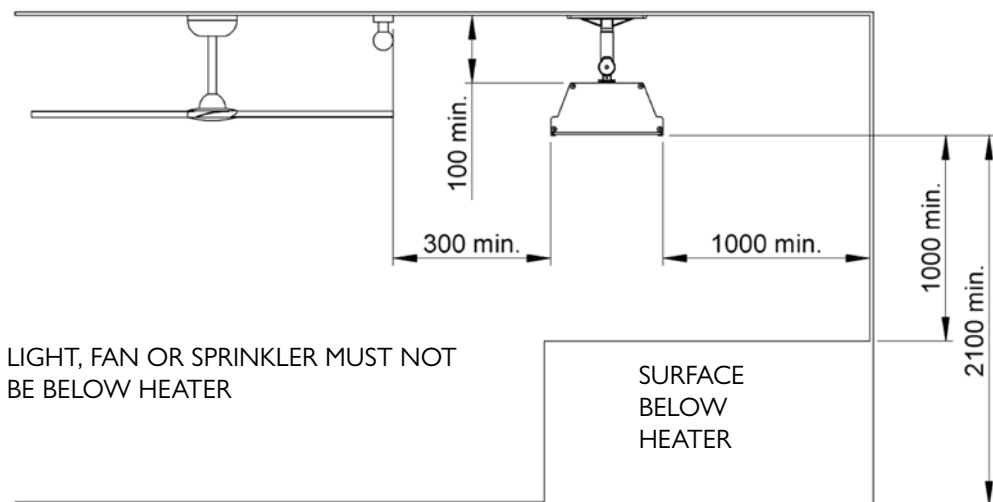

### Angled Ceiling Installation

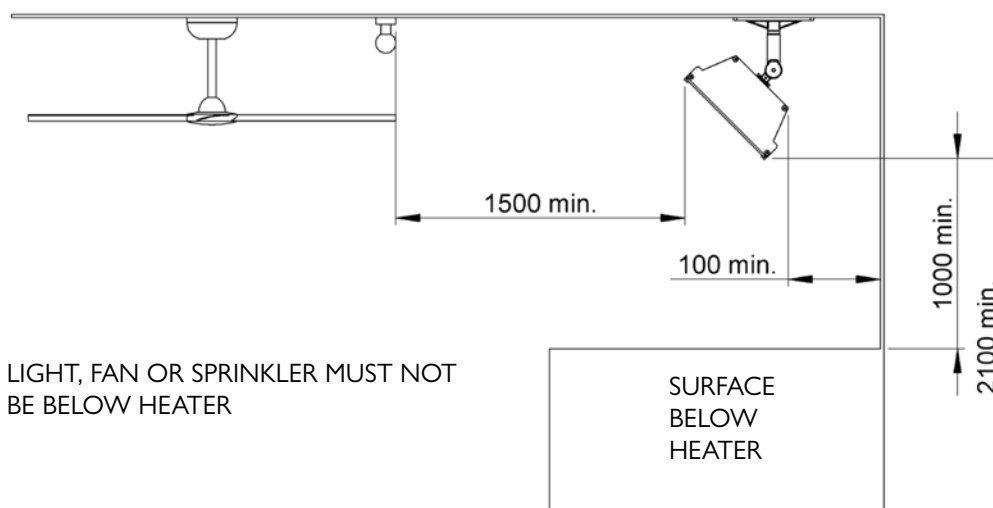



### Mounting Options

The installation of **HEATSTRIP® Max DC** is simple and easy with the standard mounting brackets supplied. For other more challenging locations there are a range of mounting options available - refer to below diagrams.

The **HEATSTRIP® Max DC** can be mounted directly to the ceiling, angled downwards on a wall, suspended on chains or poles, or attached to beams or poles. Refer to the following pages for more detailed information on each mounting option.

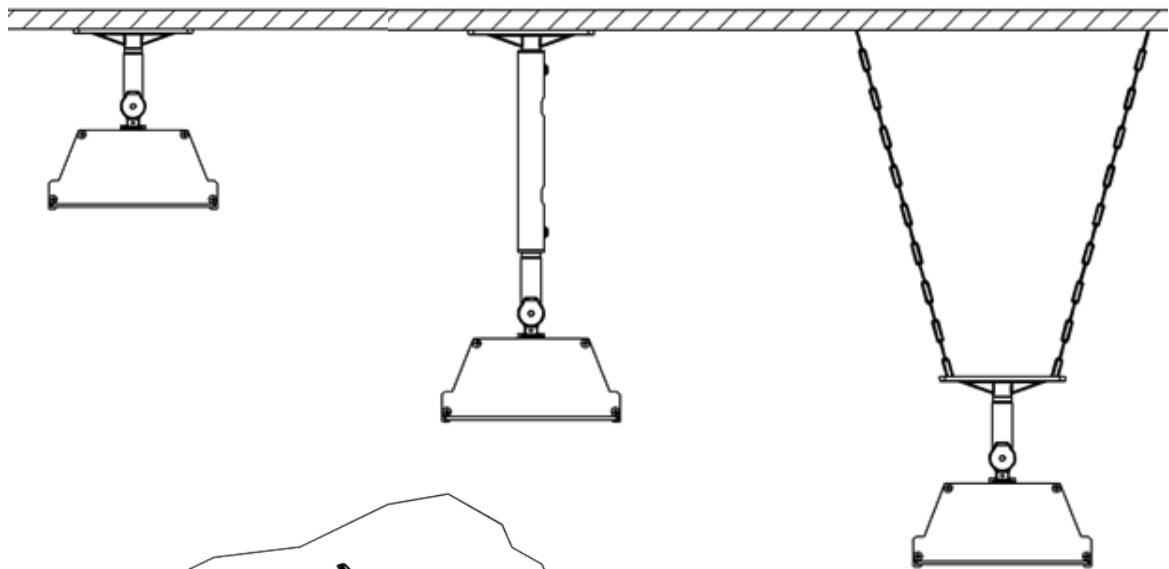

Standard Ceiling Bracket

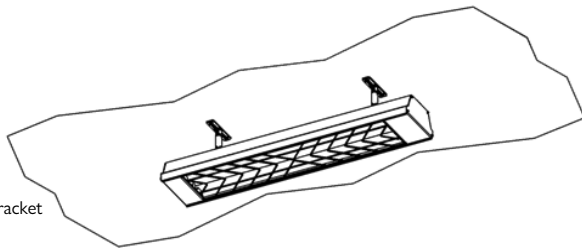

Extension Mounting Poles

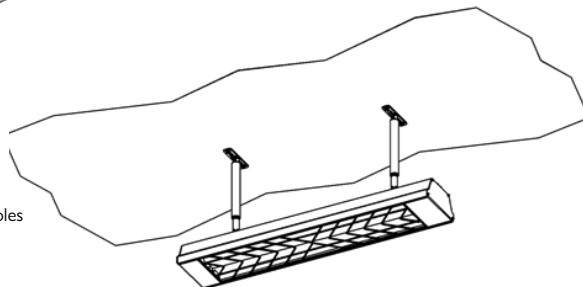

Chain / Wire Mounting  
(Using standard bracket)

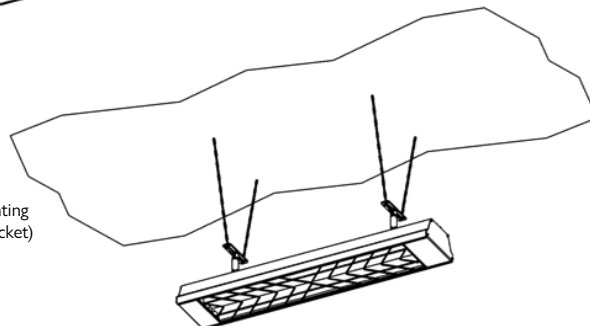

### Standard Mounting Bracket

The **HEATSTRIP® Max (THX-DC)** comes with a pair of standard mounting brackets. These adjustable brackets allow direct ceiling or wall mount, and come with pre-set angle options of parallel, 22.5° and 45°.

The flexible standard mounting bracket can be turned 90 degrees to mount onto a beam, it can also be used to suspend with chains.

The brackets need to be mounted onto a secure frame or wall with a minimum distance between the two brackets. The minimum distance (“B”) for each model is listed on the next page. All dimensions shown below are in (mm).

When completing the installation, ensure all screws are tight and unit is secure. Minimum recommended clearance is required from combustible material - if the material is non-combustible the minimum clearance is reduced

**Note:** When suspension mounting, chains are not included.

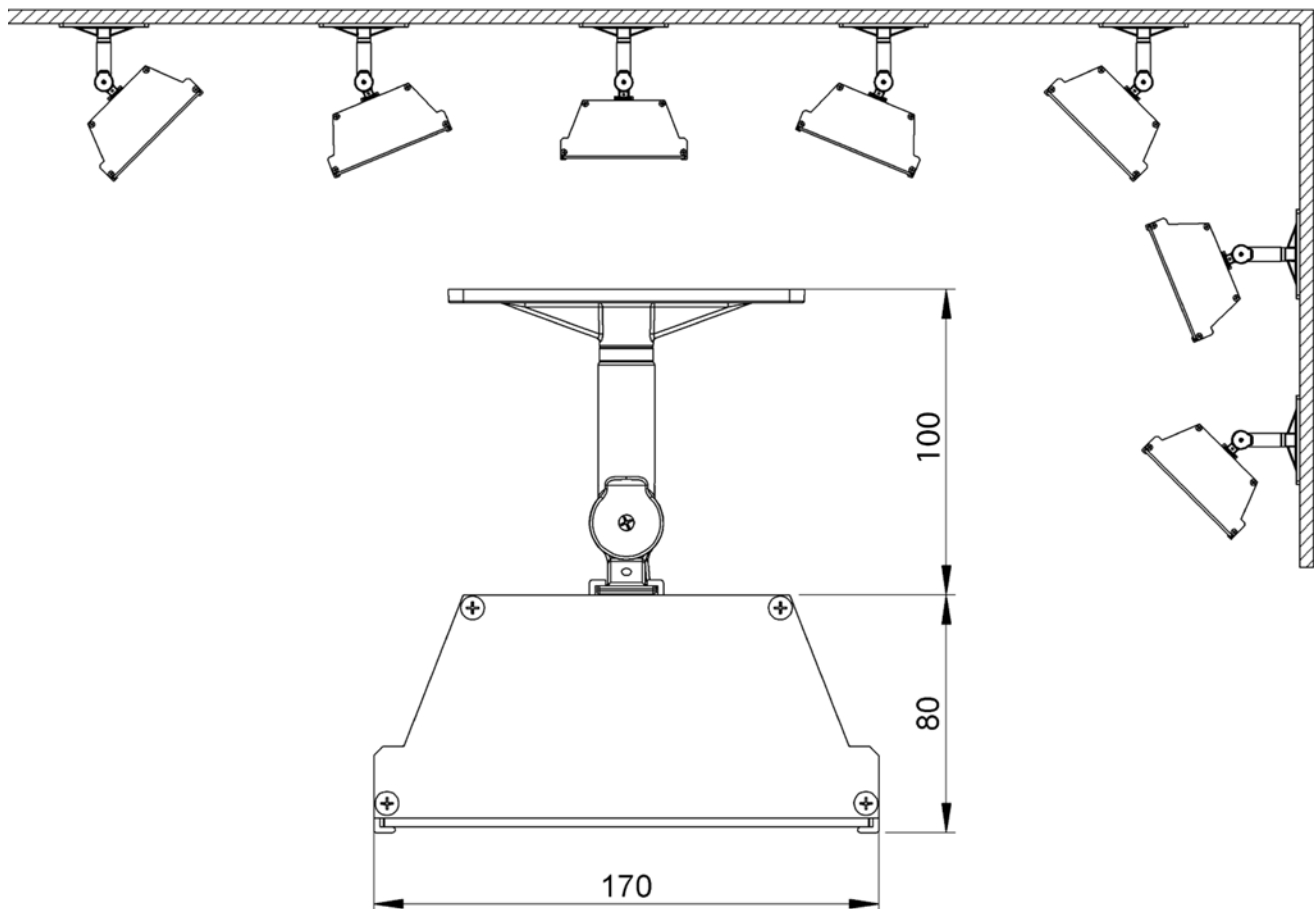

Part No.	Packaged (mm)	Weight (Kg)	Materials	Colour
ZBRAK-132B	125 x 100 x 40	0.2	Anodised	Black

### Mounting

Fix the two mounting brackets to the ceiling or wall in the desired location (refer minimum bracket centre chart). Make sure the method of fixing (bolts or screws) will be more than strong enough to support the weight of the heater, allowing for strong winds and other conditions.

- Slide the 2 locking brackets into the groove on the back of the heater. Make sure the pins on the locking bracket are facing the matching holes in the top mounting bracket.
- Lift heater into position and secure the 2 locking brackets to the mounting brackets using the screws provided. Make sure the 2 pins on the locking bracket engage with the matching holes in the mounting bracket. The pins will allow for both horizontal or angle mounting as required
- Tighten all screws and tighten the round nut at the top of the bracket, so it locks onto the top part of the mounting bracket.

**NOTE:** The standard bracket allows for normal or angle mounting of the heater and is suitable for ceiling or wall mounting.

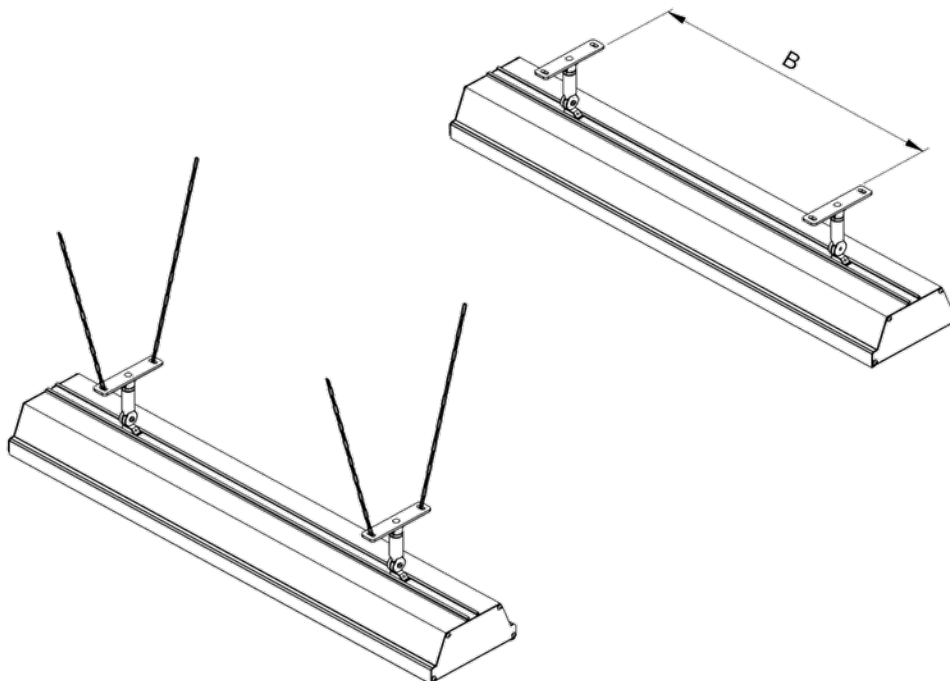

Model	"B" Minimum Distance
THX4000DC	400mm
THX6000DC	600mm

**Right:** Surface mounting, using the standard mounting brackets.

**Left:** Suspension Mounting, using the standard mounting brackets. (\*Chain not included)

## Extension Mounting Bracket

The Extension Mount bracket allows **HEATSTRIP® Max DC** units to be lowered from high ceilings, using rigid connections. The brackets are designed to be used with 20mm x 1mm round tube (SHS), and supplied as a complete kit that attaches to standard mounting brackets supplied with the heater. The standard length options as part of the kit are 300mm, 600mm, 900mm and 1200mm.

Note: Standard brackets provided with the **HEATSTRIP Max DC** heaters is required when using the extension mounting poles. \*screws to ceiling are not included.

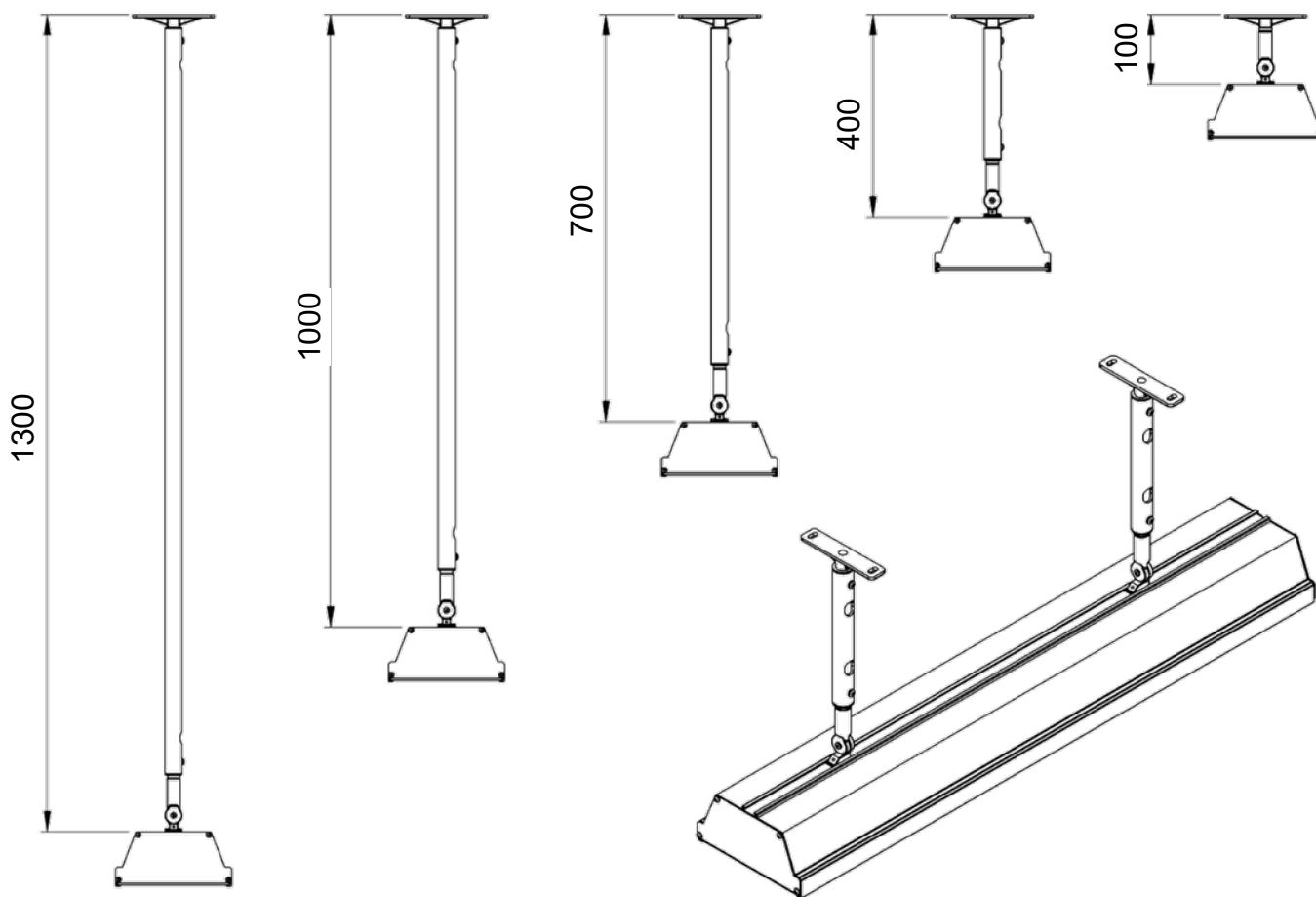

Part No.	Packaged Dimensions (mm)	Weight (kg)	Materials	Notes
THYAC - 047	300 x 150 x 50	0.21	Aluminium	Kit includes 2x300mm extension pole - Black
THYAC - 048	600 x 150 x 50	0.38	Aluminium	Kit includes 2x600mm extension pole - Black
THYAC - 049	900 x 150 x 50	0.55	Aluminium	Kit includes 2x900mm extension pole - Black
THYAC - 050	1200 x 150 x 50	0.71	Aluminium	Kit includes 2x1200mm extension pole - Black

## Maintenance

The **HEATSTRIP®** is made from durable materials, however regular care and maintenance of your heater will help prolong the life of the heater.

It is recommended that you clean the heater and with a soft cloth. Gently wipe the surfaces of the heater with warm water to remove the built up contaminants from the environment. Then rinse all detergent off the heater.

All chemicals in the atmosphere including cigarette smoke, pollution etc. will tarnish the surface of the heater. In this case, additional cleaning and maintenance may be required. The cleaning process at least every three months will reduce the amount of build up and keep it looking as best it can. If the heater is in a corrosive environment eg. salt spray, we recommend that you clean your heater with a light spray of fresh water every week. After cleaning, turn the heater on for 20 minutes to dry any water residue and prevent water staining.

Before cleaning or inspection activity, the heater must be switched off and cooled down completely.

Do not use any abrasive materials or products to clean the heater, this includes solvents, citrus based cleaners or other harsh cleaning products.

When handling the heater, ensure that your hands are clean or that you use clean gloves as grease or dirt can mark the surface of the heater.

Do not use high pressure water to clean heaters, light water spray only.

## Warranty Terms & Conditions

The below Warranty Terms and Conditions apply for **New Zealand and Australia only**. For international warranty please refer to international warranty terms and conditions.

Glen Dimplex warrants to the original owner that HEATSTRIP® Max (THX-DC) products will be free from defects in materials and workmanship for a period of 36 months for commercial applications, from the date of purchase in accordance with the following warranty terms and conditions.

Provision of this warranty is subject to:

- The HEATSTRIP® product must be installed in accordance with the Installation Instructions and relevant electrical standards and codes.
- The HEATSTRIP® product must be maintained and cleaned according to instructions detailed in the Installation Manual.
- There is no warranty expressed or implied with regard to capacity requirements. The selection of the unit or units depends entirely upon the system design and capacities as determined by the purchaser.
- The customer has not repaired, opened or altered the product in any unauthorised manner.
- This warranty excludes damage to the product or components arising from circumstances outside the control of Glen Dimplex, including, but not limited to, where the product is not used for intended purpose; where the product has been rectified in any way; incorrect installation; incorrect power supply; damaged caused during delivery; misapplication, misuse, abuse, vandalism, lack of maintenance or accident.
- Glen Dimplex's obligations under this warranty are limited to repair or replacement at Glen Dimplex's factory of any components of the product which Glen Dimplex identifies to its satisfaction to be defective.
- Transportation charges involved in return of the product to the Glen Dimplex factory (or any other location authorised in writing by Glen Dimplex) is the sole responsibility of the customer.
- All products are inspected and tested before despatch and are at the risk of the purchaser after the shipment from the Glen Dimplex factory, if not delivered by Glen Dimplex to destination.
- Discolouration of the surface may occur after a period of time, this does not constitute a warrantable event.
- Twisting and bending of the heaters may occur, this does not constitute a warrantable event.
- No products or components will be supplied in advance of an examination of the faulty product or components by Glen Dimplex or an authorized representative of Glen Dimplex.
- Glen Dimplex does not participate in any site related costs or labour expenses incidental to replacement of parts, repairing, removing, installing, servicing, transportation or handling of parts to complete products, and assumes no liability on parts repaired or replaced without written authorisation. Glen Dimplex shall not be liable for any default or delay in performance of its warranty obligations caused by any circumstances beyond its control, including, but not limited to, judicial or government restrictions, strikes, fires, floods, abnormal weather conditions, delayed supply of components.

Should products be determined as damaged on arrival, immediately notify the transport company of the condition and have them noted on the freight documents. If damage is discovered after unpacking, demand immediate inspection by the transportation company and insist that a record of the damage is made on the freight documentation.

The customer warrants using the product in accordance with:

- Any instructions provided to it by Glen Dimplex from time to time.
- All government and local regulations, including but not limited to all relevant electrical, environmental laws and regulations governing the installation, storage, use, handling and maintenance of the goods.
- All necessary and appropriate precautions and safety measures relating to the installation, storage, use, handling and maintenance of goods.

*Our goods come with guarantees that cannot be excluded under the Australian Consumer Law. You are entitled to a replacement or refund for a major failure and for compensation for any other reasonably foreseeable loss or damage.*

*You are also entitled to have the goods repaired or replaced if the goods fail to be of acceptable quality and the failure does not amount to a major failure.*

All warranty requests for repairs or replacements must be accompanied by a complete "Warranty Claim Form" available from Glen Dimplex, together with proof of purchase (and where possible, photos of the installation) and the heater returned to the place of purchase.

In the event of a warranty claim, the goods need to be returned to the distributor/retailer for repair/replacement. Contact

Glen Dimplex Australia Pty Ltd  
8 Lakeview Dr Scoresby, Victoria 3179, Australia  
Telephone: 1300 556 816 (AU) & 09 274 8265 (NZ)  
Email: [HyperCare.Support@glendimplex.com.au](mailto:HyperCare.Support@glendimplex.com.au)

